



Energy efficiency monitoring and active control solutions

Controls

Energy efficiency

From a cultural change the energy saving

■ The new challenges for the energy sector

As stated by IEA, the International Energy Agency, "Energy efficiency is a vital component to meet the challenges faced by the energy sector, which range from ever global increasing energy demand, to concerns about energy safety, rising energy costs, climate change, local air pollution, and the affordability of energy supply". In this respect, monitoring of energy matters, as a first step, for the achievement of energy efficiency goals.

Energy efficiency is "the first fuel": it is the key for cost effective energy transitions and the single energy resource that all countries own in abundance. Strong energy efficiency policies are vital to achieving the key energy-policy goals.

■ Global spending on energy efficiency

After years of weak or no growth in the second half of the last decade, energy efficiency-related end-use investment began to rise strongly in 2021. This was driven by government stimulus programmes in the buildings sector and a recovery in transport investment, after declining by around 50% in 2020 due to the pandemic.

In 2022, strong overall growth continued, with transport overtaking buildings as the main sector for increased spending, driving total efficiency-related investment up by 16% to just over USD 560 billion. Under current expected policies, efficiency-related investment is projected to rise by a further 50%, to almost USD 840 billion per year by 2026-30. However, these levels are only about half of the energy efficiency-related investment needed in the second half of this decade to meet the Net Zero Scenario goals.

Massive efforts to accelerate investments in building efficiency and electrification of transport, heating, cooling and industrial production are required to realise global climate ambitions.

In the Net Zero Scenario of the WEO 2022 (World Economic Outlook), the share of investment in energy efficiency and electrification rises from 17% of the current total to 32% by 2030, and 40% by 2050.

Global energy efficiency-related end-user investment 2019-2022 and average scenario 2026-2030

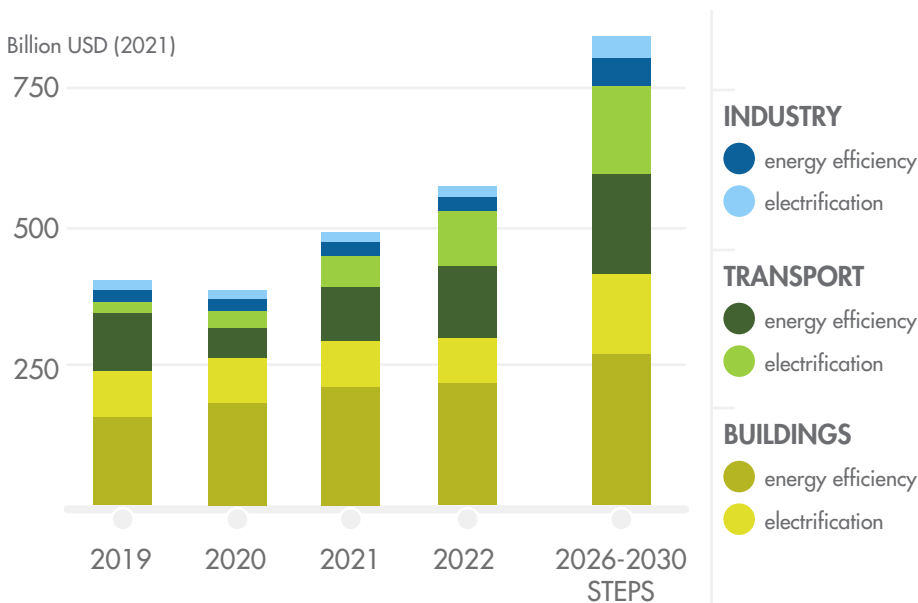

■ Why the plan-do-check-act cycle

To be able to respect Energy Efficiency mandatory regulations and goals, and therefore to achieve both Energy and cost savings, it is important to plan a proper "Energy Efficiency Plan", which has to be based on a PDCA (Plan-Do-Check-Act) cycle. An Energy Efficiency plan, if related to a medium or large installation, has to go through an Energy audit which enables to assess:

- **critical issues** within a site;
- **priority** of the corresponding resolution;
- **areas of action** to be developed which can be implemented either during the design phase of a new system or during the renovation of an existing one.

■ The three major steps

An Energy audit and subsequently an Energy efficiency plan is split in three major steps: checking, monitoring, and analysing the actual use of Energy. If the statement: "do not estimate when you can calculate, do not calculate when you can measure" is obvious, the logical consequence is splitting the whole plant into main and sub-metering to identify the electrical energy wastes.

■ All areas have to be fully implemented

But such a plan is not complete if the identified areas of actions are not fully implemented. This means that lighting, cooling, space heating controls and a proper BACnet communication capability to an HVAC system are mandatory conditions to achieve the needed Energy and cost savings.

■ The right solution

Thanks to its comprehensive solutions, including meters, data analysis, communication technologies, and controls, Carlo Gavazzi provides all the information necessary to implement, by means of functions like KPIs (key performance indicators), benchmarking, reporting, and the management of the base line, all the automatic tools necessary for the measurements provided by the energy efficiency implementation plan.



The multiple benefits of energy efficiency

Energy efficiency

UWP the paradigm shift

■ How can you implement an effective Energy Efficiency plan?

Meters are useless if relevant data cannot be collected remotely, and remote collected data is useless if not fully automated and properly filtered for a focused analysis!

Nevertheless, an energy efficiency plan is not effective, and savings cannot be achieved if the automatic data analysis does not act properly on loads. Therefore the paradigm is to be able to generate useful information and to automatically convert it into saving actions. A System Integrator in such a situation would combine components from different suppliers to achieve the requested model. The paradigm shift is to be able to provide to the same user a unique complete, flexible and scalable platform.

■ Why a unique platform?

A System Integrator using a standard monitoring and control architecture would face the following problems: system complexity, cost issues, a long commissioning time, a long learning time. The same System Integrator, using UWP "Universal Web Platform" as the core of the Energy saving system would benefit of architecture simplicity, short commissioning time, cost reductions, error proof configuration, expandability, and scalability. The UWP web platform with full functionalities meets today's Energy Managers and Energy Service Companies requirements to achieve energy efficiency goals.

■ An open system!

UWP is the heart of a powerful system, it acts as a web server and a gateway which embeds various communication protocols such as Modbus TCP/IP, BACnet, SFTP, Rest API, etc. To meet the growing integration demands of IoT and cloud-based Industry 4.0, UWP is certified for Microsoft® Azure IoT.

More specifically: FTP, SFTP, FTPS sends data securely and reliably on a schedule to a standard FTP server. Rest API enables the exchange of data with remote systems with the necessary flexibility. Modbus/TCP and BACnet bridges available data points using UWP as a flexible data hub between fieldbuses.

UWP is Microsoft® Azure certified for IoT. The available data points are sent via MQTT to the Azure IoT platform allowing users to stream data from multiple UWP units to a centralized SQL or non-SQL database and from here to leverage the powerful tools from the Microsoft® Azure marketplace to analyse, organize, aggregate, and display data. In order to extend the integration capabilities of UWP now also AWS IoT Core certification is available with all the advantages provided by the relevant services.

Disclaimer

Microsoft®, Azure, SQL Server are registered trademarks of Microsoft®. AWS and AWS IoT Core are registered trademarks of Amazon Web Services. Carlo Gavazzi has no commercial relationship with neither Microsoft® nor Amazon Web Services. Therefore all the Microsoft® and the Amazon Web Services solutions mentioned in the document must be purchased and supported through the Microsoft® and the Amazon Web Services commercial channels.



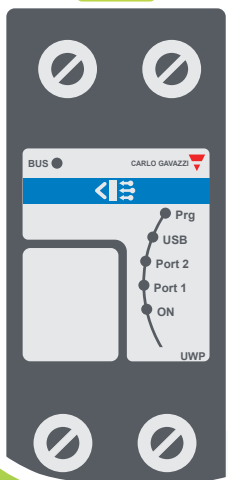

UWP

Gateway

Monitoring, data analysis and reporting

Wide control possibilities

Cost streamlining and energy saving

Energy efficiency

The UWP WEB platform family

■ Why UWP 3.0 SE and UWP 4.0 SE

UWP 3.0 SE is the universal web platform specifically designed for small to medium installations, while UWP 4.0 SE is for large installations where key factors are:

- scalability easy to implement so to easily follow the expansion of the facility;
- management of an extended number of measuring points for main electric parameters monitoring;
- management of an extended number of lighting systems;
- management of DALI-2 allowing not only the lighting control including the management of the tunable white but also the possibility, on the same bus, to manage inputs from contacts and signals from sensors such as temperature, humidity and others.

■ UWP 3.0 SE vs. UWP 4.0 SE main features

FIELD	SHORT DESCRIPTION	UWP 3.0 SE	UWP 4.0 SE
Hardware	Modem connectivity	Yes, by using SH2DSP24	Yes, direct connection to USB
	RAM	128 MB	512 MB
Software	Configuration software	UWP3 tool (WIN)	UWP IDE (WIN)
	Communication port	Fixed	Editable
	Application selector	Fixed, all function shown	Editable, energy and building automation group
Web App	User	2 users	Multiuser with editable read/write rights
	Functions editing	Not allowed	Yes
	Rename signals	Not allowed	Yes
	Alarms report and management	No	Yes
Protocols and IoT	BACnet	500 objects	1000 objects
	API	REST, read	REST, read/write
	DALI-2	No	Yes

■ The Cybersecurity as core part of the UWP web platform

The importance of cybersecurity in Energy Management Systems

A secure system is made up of secure components: how can you claim that your component is secure?

Very often it seems that by adding some extra security software or hardware is the only way to go.

The right advice is based on minimalism: limit the number of components in use to the bare minimum and make sure that all of them are secure enough for the application; the point is how to evaluate cybersecurity of a component.

The best way is to rely on trusted certification or ratings: a product which has undergone a cybersecurity rating or certification by a cyber lab with a good reputation gives you peace of mind that your defences will protect against the vast majority of common cyber attacks.

The EDGE level is possibly the most critical: being at the same time in contact with the operational technology (OT) part in the field and the information technology part (IT) in the cloud, it is the most sensitive brick in the IIoT paradigm. A strong EDGE level is for sure a robust foundation on which to base the whole architecture.



The UWP platform is the IIoT gateway and controller by Carlo Gavazzi for EMS systems. It is the core of an ecosystem of more than 200 meters, sensors, actuators by Carlo Gavazzi. Besides, it can be connected both at field level and at cloud level to other systems so to play as the EDGE tier in an EMS architecture. Carlo Gavazzi is committed to provide the best security level to customers and users; for this reason, both UWP 3.0 SE and UWP 4.0 SE security capabilities have been verified by UL, one of the top worldwide laboratories for cybersecurity assessment and advisory. An official rating represents a solid and secure reference for the product selection. By having solid networking foundations and encouraging customers to protect their system via VPN and passwords, the UWP Web Platform is one of the first EDGE products in the market with an official cybersecurity rating.

The need of remote connection for end-users and system integrators is almost mandatory. Typically, users want to control their devices from their smart phones, and system integrators prefer to connect from their office to their customers' plant for solving problems. This way, they avoid trip and consequently save time and money. As is already well known, a system where end points are connected to network and each other through smart devices, cyberattacks risks - and in general cybersecurity issues - grow exponentially. A solution to protect their remote access to the target system is a secure Virtual Private Network (henceforth VPN) tunnelling.

The VPN is the best choice to provide end-users and system integrators of end points with a secure remote access to smart phones, PC and IoT without threatening the network cybersecurity.

The goal is to guarantee the interconnection among devices, from device to external and the access to devices from outside, without mining the IT security and the sensitive data protection. The wellknown Internet services are conceived to be accessed by everyone; the so-called "public network" servers and the sensitive data are subject of fraudulent users' intrusions.

The creation of a private network (VPN) permits isolating a company network by using an IP address unreachable via Internet, with restrictions permitting the access only from external authorized devices. Moreover, the private network can be extended beyond the public network with an encrypted virtual connection.

The Carlo Gavazzi VPN for building efficiency applications is MAIA Cloud. It is a PaaS (Platform as a Service) solution that allows a seamless connection of different remote devices, through both UWP 3.0 SE and UWP 4.0 SE gateways, so to develop the necessary energy efficiency monitoring and building automation solutions by connecting and setting the relevant items. Users who have access to the MAIA Cloud can easily reach the gateways and the endpoints, provided they have the necessary access rights, using a PC application called MAIA Cloud Connector.

By connecting to a centralized web portal, with a secure login, users can reach their fleet of UWP 3.0 SE and UWP 4.0 SE units. Permissions for specific users or groups of users can be set by the organization administrator so to prevent any misuse. The VPN tunneling technology permits to set a secure encrypted channel between users and IIoT devices; the authentication procedure secures the access to the portal endpoint.

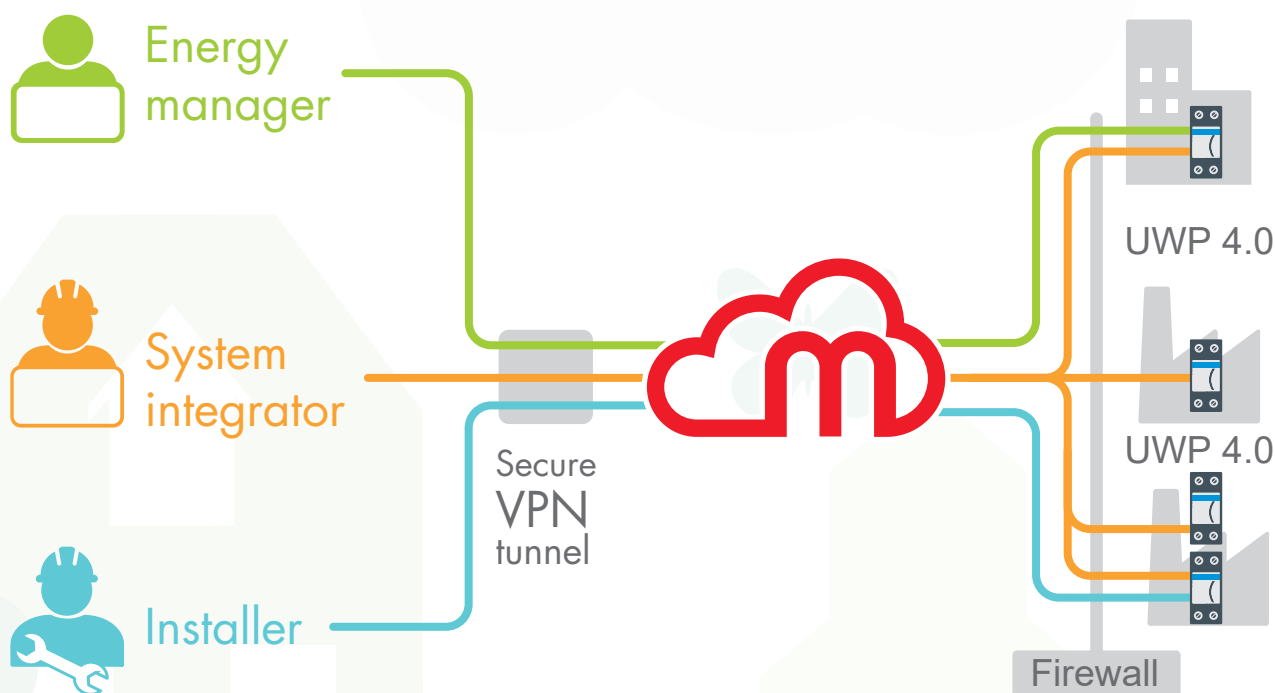

MAIA Cloud in energy monitoring and building automation OT (operation Technology) use case. Users according their roles have access to the endpoints (EDGE or FIELD devices) located in different plants. MAIA Cloud allows users with specific permission to send commands to endpoints or monitoring and manage data remotely.

Monitoring

The map

■ The Carlo Gavazzi Energy Efficiency Monitoring competences

This map guides you, in this example, through the Carlo Gavazzi competences and product solutions. A journey through protections, EScO analysis tools, core units, utility meters, data acquisition and integration solutions. Integration of main and sub-metering systems in existing and new installations!

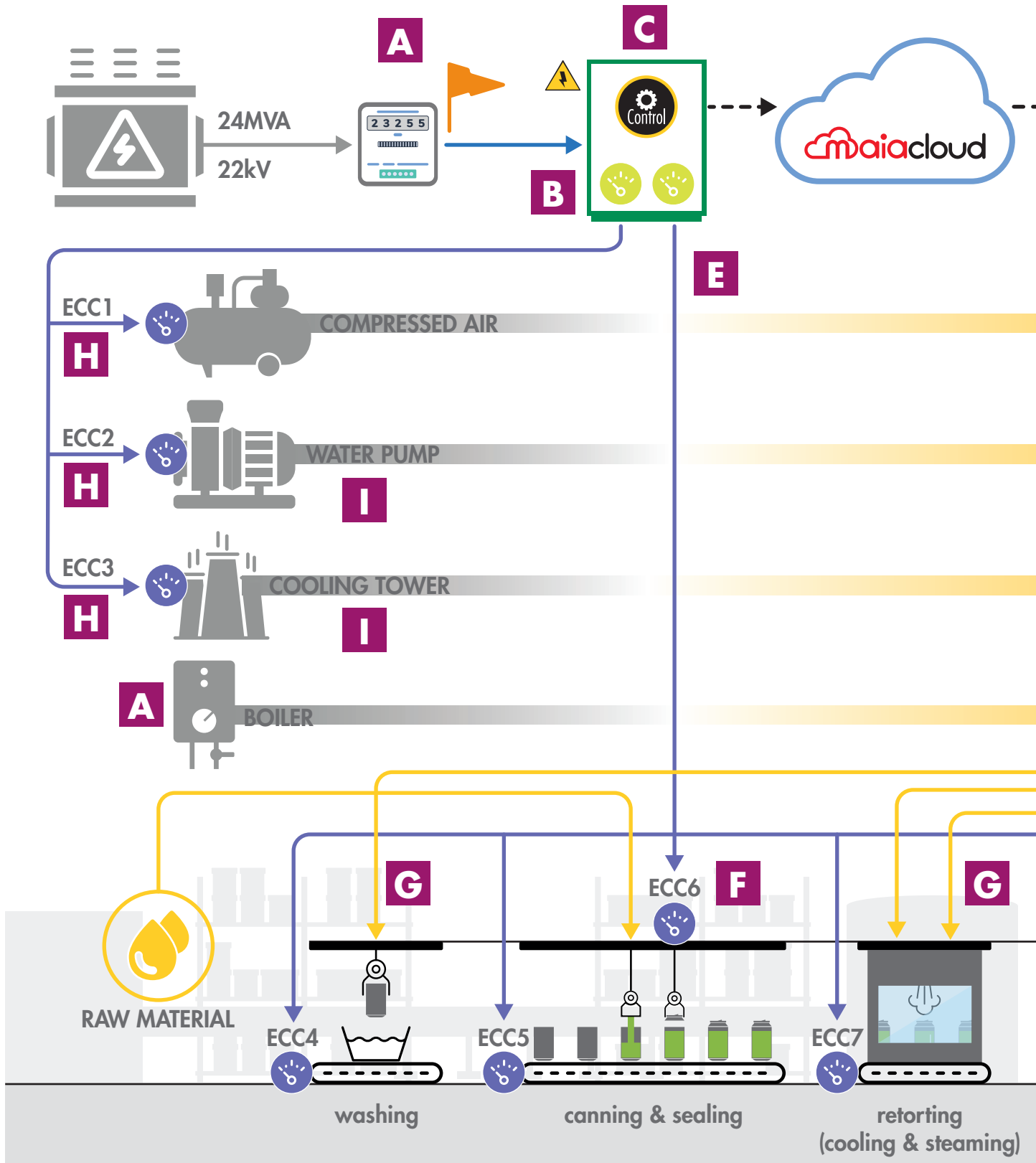



To grant the full interoperability of some of its meters, Carlo Gavazzi is now member of the OMS Open Metering System group.

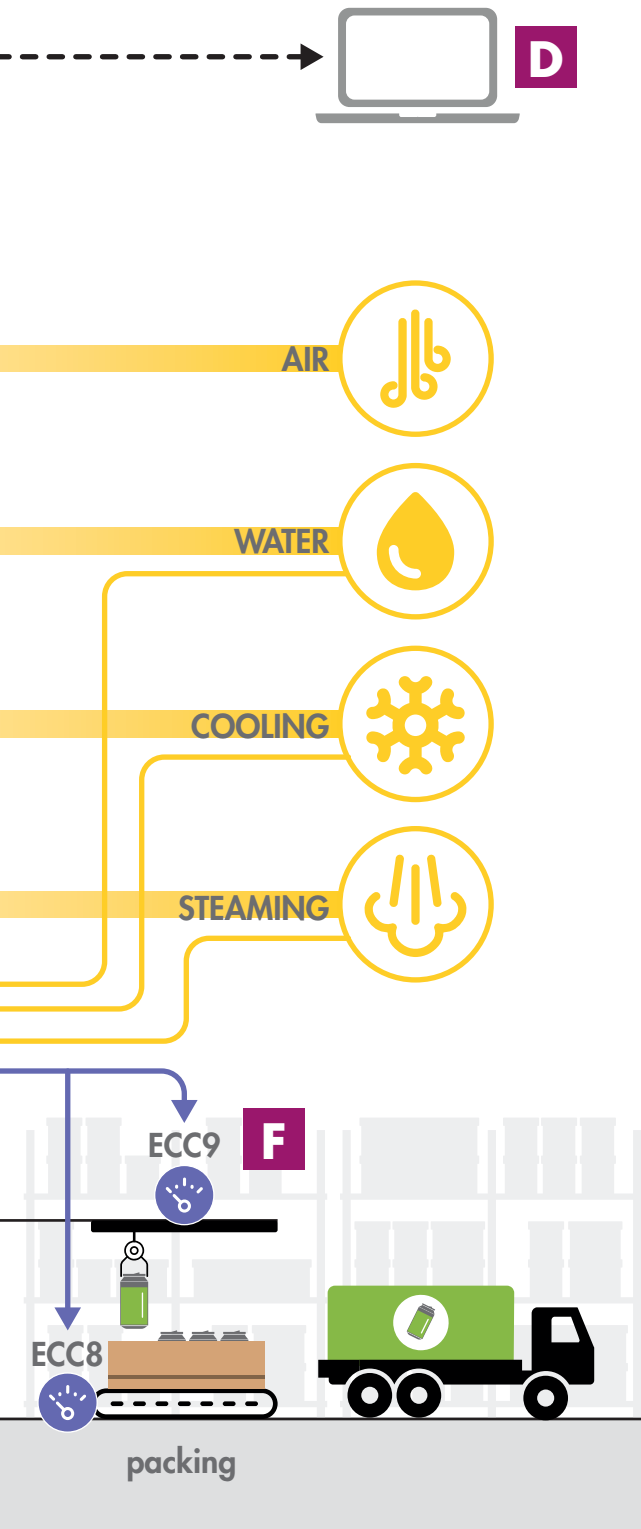

 **Utility-meters**

 **Main-meters**

 **Sub-meters**

ECC: Energy Cost Center

The topics

	Page
A Integration of existing utility, main and sub meters	10-11
B Protection and monitoring	12
C Web platform	14-15
D On premises and cloud solutions	16-19
 Long range wireless communication	20-21
E Modular main metering with power analysis	24-25
F High density metering	30-31
G New installation main and sub metering	22-23 26-29
H Existing installation main and sub metering	13
I Critical loads ON/OFF status	32-33

All products in this document are both CE and UKCA compliant

Monitoring

Utility, main and sub meter integration

Existing utility metering

The utility meters are sources of valuable, unexplored, frequently unavailable information.

If the utility meters are M-Bus (EN13757) wired or wireless based, then SIU-MBC can be used as a dual pulse counter or directly via SIU-MBM which acts as a gateway. These add-on solutions make this valuable information available for your Automatic Energy Monitoring System. More specifically: if the utility meter has only a pulse output, no available auxiliary power supply, and the meter itself is far from your nearest distribution board, the solution is the wireless SIU-MBC. It is self-powered by an internal battery lasting up to 12 years, and is perfectly suited to outdoor applications; if the utility meter is wired or wireless M-Bus-based, the solution is SIU-MBM. All devices with the exception of SIU-MBC can be configured using UCS, the Universal Configuration Software for Carlo Gavazzi meters and accessories.

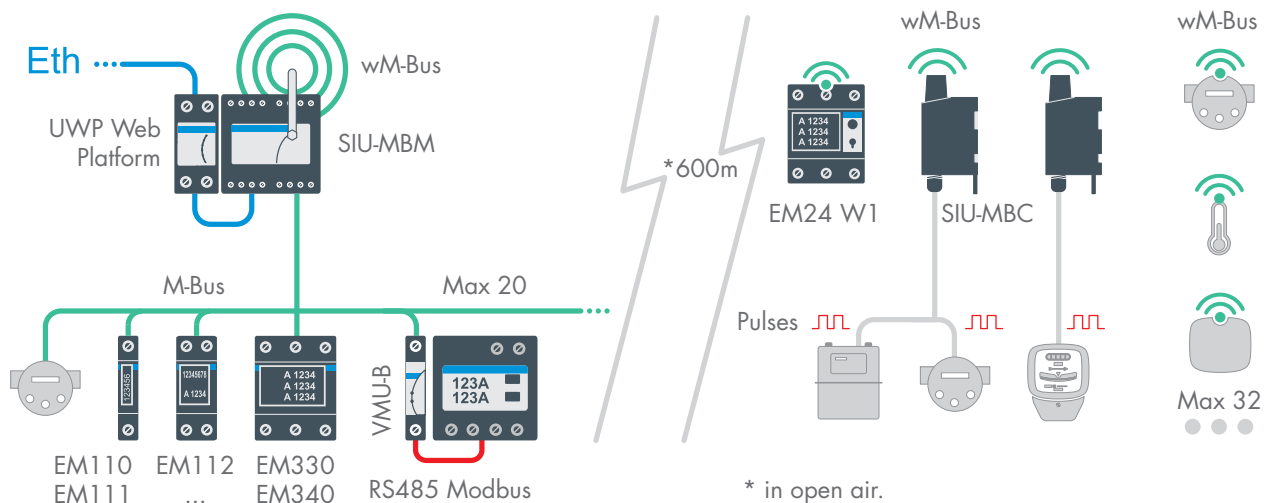

SIU-MBM 01, SIU-MBM 02

SIU-MBM 01 and 02

- Collects data from multiple M-Bus and wireless M-Bus devices
- Converts data from M-Bus and wireless M-Bus into Modbus TCP/IP
- Up to 20 connected M-Bus devices (300 to 38,400 bps), daisy chain or star connection
- Ethernet Modbus TCP/IP output
- 15 – 21 V ac, 18 – 35 V dc power supply
- On DIN rail or wall-mounted, IP20.

SIU-MBM 02

- Up to 32 wireless M-Bus devices
- Wireless communication antenna
- Frequency 868 MHz

VMU-B

- RS485 Modbus-based meter to M-Bus adapter
- One to one communication
- Meter self recognition: EM210, EM270, EM271, EM280 and WM15
- Universal power supply (18 – 260 V ac/dc)

SIU-MBC

- 2 pulse inputs, selectable scale and engineering unit, like: 1/10/100/1000 (Wh, dm³ or L)
- Wireless M-Bus, 868 MHz
- Data transmission interval: 10 s, 10 min, 12 h
- Operating range up to 600 m in open air
- Battery: lithium, Li-SOCI2 (≥12 years lifetime)
- Mechanical lock with safety seal to ensure protection degree and prevent accidental opening
- Assembly with zip ties on tube/mast or wall-mounted with screws or on DIN rails
- Anti-fraud system, IP67

EM24 W1

- CT 5 A, 230 – 400 V L-L ac measuring inputs, 115 – 230 V ac power supply
- 65 A, 230 – 400 V L-L ac measuring inputs, self-power supply
- 4-DIN modules housing
- 3 counter digital inputs
- 2*8-digit LCD
- Single and three-phase measurements: V, A, Hz, PF, W, VA, var, run-hour, kvarh, 4-tariff, 3*1-phase kWh
- Basic accuracy (V/A): ±0.5% RDG
- Bi-directional kWh (cl. B EN50470-3 MID approved)
- wM-Bus wireless communication
- Two antenna options: external or built-in



Existing main and sub metering

Already installed pulse output-based meters can still be part of a data collection system!

In many installations, old fashioned meters are still working properly but energy information is still collected manually with both high data collection costs and potential transcription errors. Now, concentrating on multiple meters' pulse outputs and making them available as RS485 Modbus counters is possible, thanks to the modular VMU-MC + VMU-OC solution ranging from 2 to 11 pulse inputs (counters). Pulse to Modbus conversion is the key to automatic data collection, which ensures quality, granularity, and full management of data.

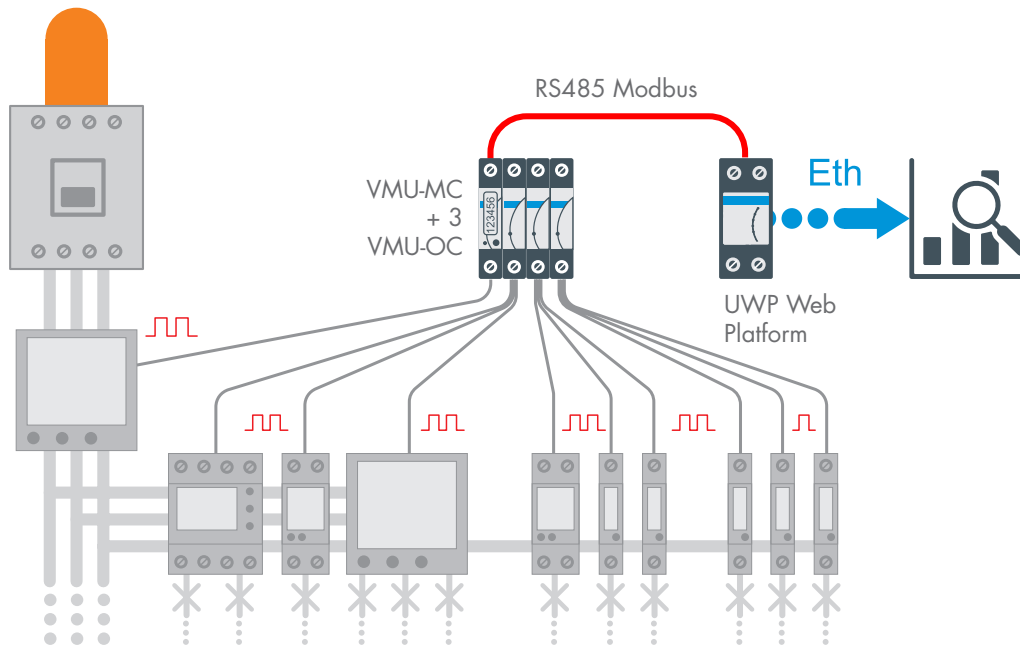

VMU-MC, VMU-OC

- 1-DIN module housing
- Modular
- RS485 communication port
- 11 total inputs available
- Unit of measure: kWh, kvarh, kVAh, kJ, kcal, m³, Nm³, h, pcs, kg

VMU-MC:

- LCD display for: status, counter, any active tariff
- 2 inputs available (for pulses counting or for up to 4 tariffs selection)

- 15 – 24 V dc power supply

VMU-OC:

- 3 inputs available (for pulses counting only)

■ The UCS software configuration advantages extended also to VMU-MC and VMU-OC!

UCS features for configuring devices, storing configurations into a database, sharing configurations and logs among users, and checking the device status are available also for VMU-MC/OC. Therefore the two VMU-MC inputs can be set as counters, or one as a counter and one to sense tariff change as a digital input, managing automatically the energy increase for both tariff 1 and tariff 2. Every counter input and function has an independently configurable pulse weight.

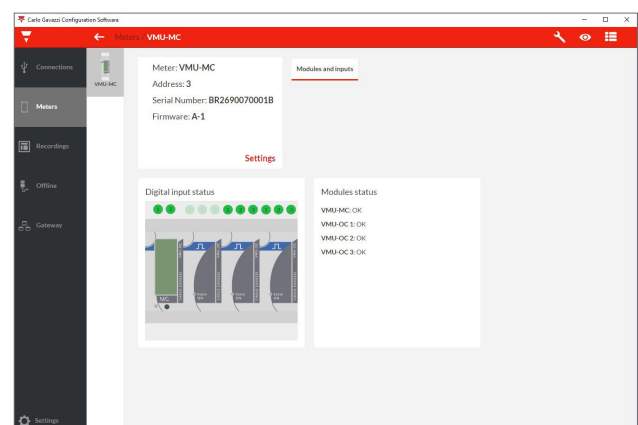

Monitoring

Protection and monitoring

Electrical safety as part of the EEM solution

Why installation protection?

How to prevent injury? In the wide range of protection devices, there is a family of units called RCD Residual Current Device. The purpose of an RCD is to prevent threats to life by protecting against the risks of electrocution and fire caused by earth faults.

How to detect dangerous earth leakage currents? In industrial and commercial applications, due to their specific requirements, the device used is called an MRCD Modular Residual Current Device. More specifically, it is an earth leakage current relay which can detect by means of an external core balance transformer the earth leakage current.

How to avoid power supply interruption? Both RCDs and MRCDs are prone to nuisance trips from normal harmless earth leakage. Those are due to external factors, such as a high current discharge due to lightning or to an earth rod placed close to a neighbouring earth rod on a building. A nuisance trip would affect the availability of power supply, which for example in a production facility, because of its nature, is not allowed.

The Carlo Gavazzi solution is made of two models: DEA71 and DEB71, combined with CTG, our core balance transformer family. Our MRCDs comply with IEC/EN 60947-2, so to avoid nuisance trips and fulfil the "A" type operating characteristic so to work in case either of presence or absence of DC component of residual currents.

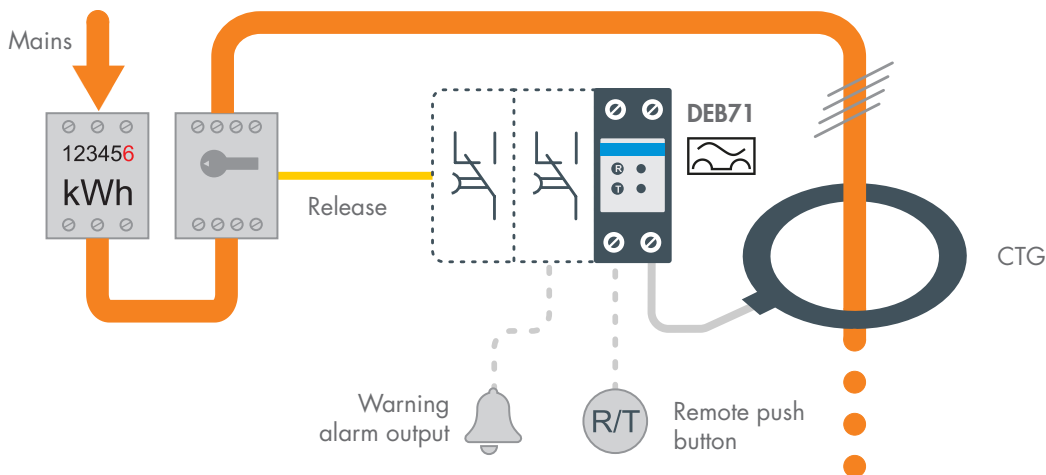

DEA71

- Fixed current setting: 30 mA or 300 mA
- 2 relay outputs for warning and alarm
- Input for remote Reset / Test
- 24 – 240 V ac power supply



DEB71

- Adjustable setting from 30 mA to 5 A
- Adjustable delay up to 5 s
- Leakage level LED bar
- 2 relay outputs for warning and alarm
- Input for remote Reset / Test
- 24 – 240 V ac power supply



CTG, core balance transformer

- Easy installation
- High accuracy and sensitivity

Model	Hole size (mm)
CTG35	35
CTG50	50
CTG70	70
CTG120	120
CTG160	160
CTG210	210

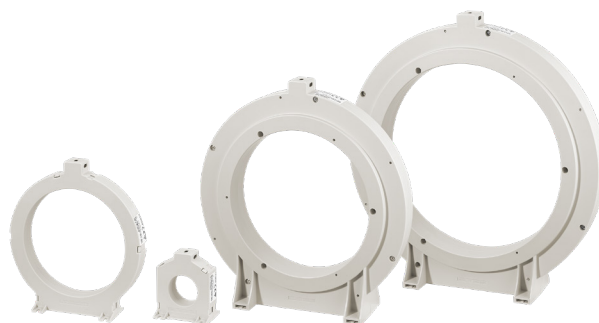

Retrofit main and sub-metering

The “check” part of the PDCA process starts here!

Identifying areas of energy wastage with a quick installation. This solution is suitable for ESCOs, being possible to easily remove equipment from a place where it has been installed, and re-install it somewhere else. But it can also be the ideal solution as a part of a permanent monitoring system in a plant where space and communication capabilities may be restricted.

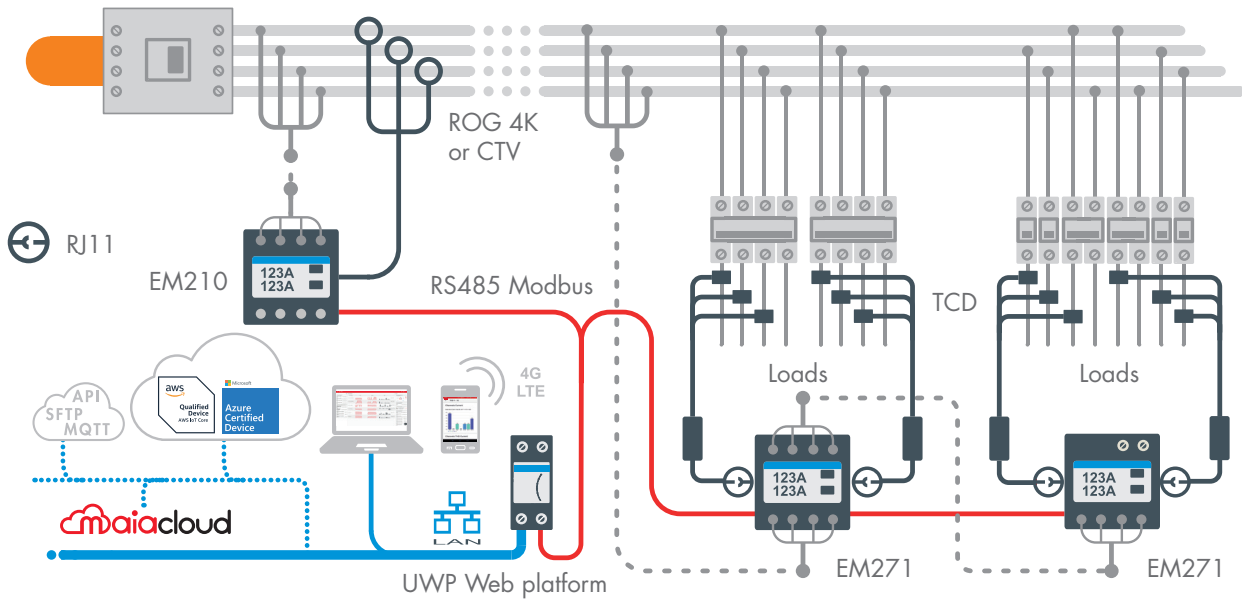

EM210, main metering solution

- Patented meter, 4-DIN and 72x72 mm solution in the same housing for DIN-rail or panel mounting. Detachable 3*3-DGT/7-DGT display
- Up to 415 V L-L ac and CT/CTV/ROG-based current measuring inputs
- 5 A CT (AV version), 333 mV from CTV 1X-2X-3X-4X-6X-8X sensors (MV version), Rogowski current sensors (MV version)
- Measurements: V, A, Hz, PF, W, VA, var, bi-directional kWh
- An (calculated), THD up to 15th harmonics
- Pulse output and RS485 Modbus RTU (up to 115 kbps) port
- Self powered (230 V ac)
- Basic accuracy (V/A): $\pm 0.5\%$ RDG, kWh class 1 (IEC/EN 62053-21)
- Class B (EN50470-3), MID approved (AV version only)

CTV and ROG 4X series, sensing solutions

- **CTV 1X-2X-3X-4X-6X-8X.** Split-core current sensing unit, 333 mV output.

Model	Primary (A)	Hole size (mm)
CTV 1X and CTV 2X	60 and 100	9.6 and 15.5
CTV 3X, CTV 4X and CTV 6X	200 and 400	15.5, 20.5 and 36
CTV 8X	800	50*89.8

- **ROG 4X.** Rogowski coil current sensors. Primary: 20 to 4000 A, diameters: 90, 120, 200, 290 mm

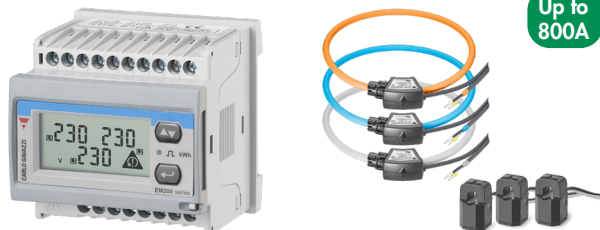

EM271, sub metering solution

- Patented meter, 4-DIN and 72x72 mm solution in the same housing for DIN-rail or panel mounting. Detachable 3*3-DGT/7-DGT display
- Up to 415 V L-L ac and TCD-based current measuring inputs
- Current measurement by two basic TCD units with quick RJ11 plugs (see TCD xM series)
- Quick configuration by automatic recognition of TCD units
- 2*3-phase energy analysers with sum function in the same unit
- Measurements: V, A, Hz, PF, W, VA, var, bi-directional kWh
- RS485 Modbus RTU. 2 pulse outputs (loads 1 and 2)
- Self powered (230 V ac)
- Basic accuracy (kW): $\pm 2.0\%$ RDG (meter + TCD xM unit), kWh: class 1 (IEC/EN 62053-21)

TCD 0M-1M-2M-3M, MM sensing solutions

- Combination of three single split-core current sensing units

Model	Primary (A)	Hole size (mm)
TCD 0M and TCD 1M	60 and 100	9.6 and 15.5
TCD 2M and TCD 3M	200 and 400	15.5 and 20.5
TCD MM	Up to 10000(*)	See CTV series

- Basic TCD xM unit (connected to three current sensors) for panel and DIN-rail mounting
- (*) Compatible with current sensors with 333mV output



Monitoring

An optimized platform for monitoring

Communication, analysis and reporting in one unit

UWP with UL certified cybersecurity is the core of this web platform and also the unit with the task to analyse the plant variables being managed to achieve the energy efficiency goals.

UWP is the core of the entire system and can provide, as a first step, all the remote, on-premise, or cloud functionalities. Simple architecture, short commissioning time, cost reductions, error proof configuration, expandability and scalability are the distinctive characteristics of this unit. UWP is a Web-Server but also a gateway. UWP is Microsoft® certified for IoT. One or many UWP pushing their data to the Microsoft® Azure IoT Hub will allow System Integrators to extend the level of integration to other systems. Data can be shared locally via Modbus/TCP or BACnet, while M2M makes integration with other systems possible via Rest-API or standard FTP, SFTP, FTPS communication. Excel® reports can be generated online or via the embedded scheduler. Whenever ESCOs and Energy Managers need a solution for taking control to achieve their Energy Efficiency goals, UWP provides a solution to match the existing scenario.

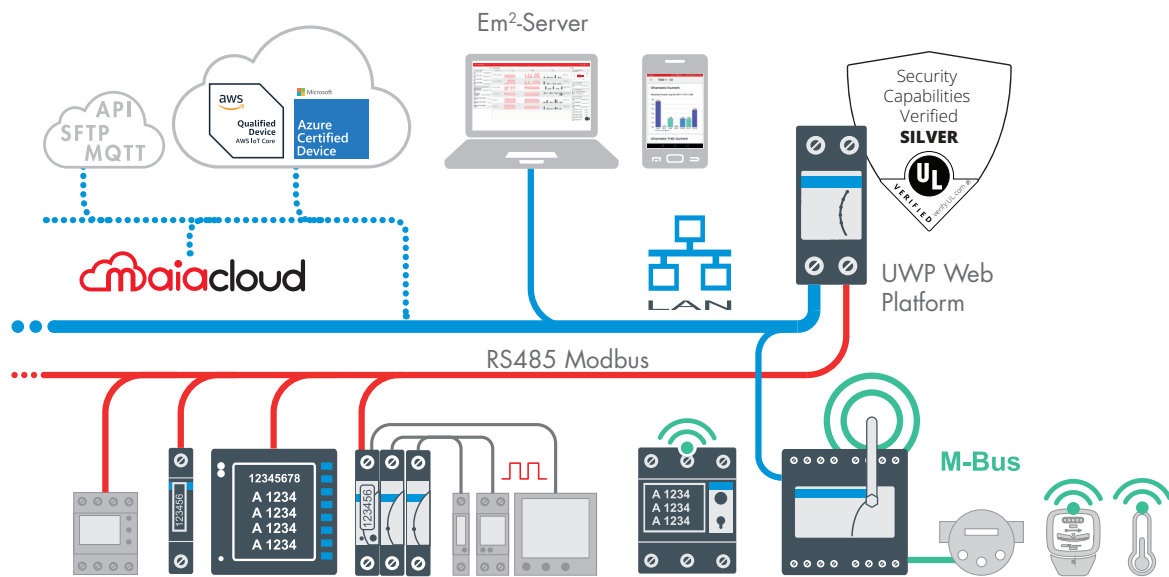

UWP 3.0 SE

- Micro PC with embedded Web Server, WEB services and data logger functions
- Ethernet Modbus TCP master/slave function
- 2 x RS485 ports, both of which support up to 64 Modbus devices
- Data display (charts and tables)
- Real time or scheduled data export to Excel, CSV and HTML formats
- 4GB internal memory, Back-up memory on micro SDHC and USB
- Energy analysis of each load
- Configurable dashboards with data analytics and real time display functions
- Embedded Modbus editor for compatibility with any Modbus meter
- Alarm management (e-mail or SMS by means of SH2-DSP)
- BTL certified (max 500 BACnet points for used BACnet objects)
- 12 – 28 V dc power supply
- 2-DIN module housing

SH2-DSP

- Modem extension unit only for UWP 3.0 SE
- 3G or 4G Mobile Internet connectivity with SMS alerts and SMS commands management
- 2-DIN module housing
- 20 – 28 V dc power supply

UWP 4.0 SE

Main features like UWP 3.0 SE

Specific characteristics:

- Embedded automation server allows data to be exchanged locally or remotely via standard Internet protocols such as: FTP, SFTP, FTPS, SMTP, Rest-API, MQTT, Modbus and BACnet
- Complete lighting control system based on DALI-2
- BACnet/IP gateway operation
- Up to 5000 managed signals (including variables, I/Os)
- Up to 5 users concurrently connected to the Web-App
- Up to 5 concurrent M2M connections (API connections, BACnet clients, Modbus masters)
- BTL certified (max 1000 BACnet points for used BACnet objects)
- USB port for external modem management



Tools to properly display the key variables

The UWP unit allows you to automate the process of collecting data points from multiple meters.

The embedded Web-Server allows you to remotely display the key plant variables using analysis tools such as tables, trends, histograms, pies, comparison functions, and others. The system allows gathering, displaying, and logging variables from any meter or device connected to the available field-buses. Dashboards mixing both history and real time data allow users to take control of their data.

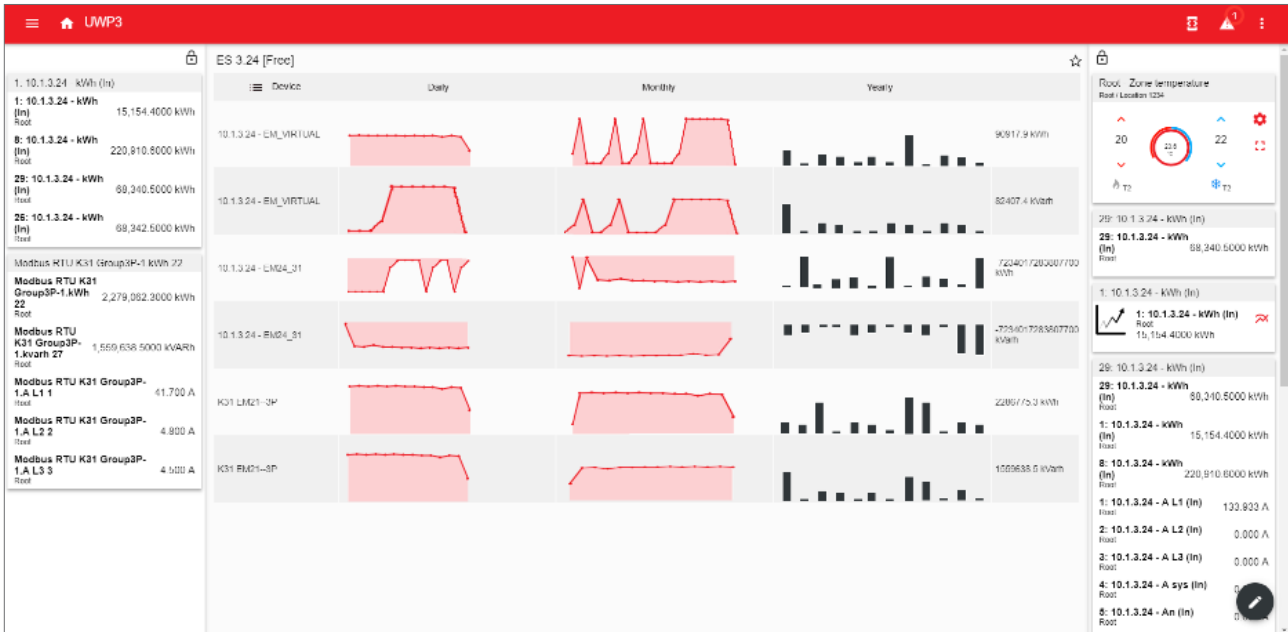

Monitoring

On premises and Cloud solutions

A scalable architecture made of building blocks

It is a matter of fact that a small to medium Company or a large multinational have different needs in terms of organisation and management.

It is also obvious there is a connection between facility dimensions, management complexity and quantity of data being generated. At the end, the management of needs, becomes sooner or later the management of problems. In the specific case of data, it is therefore important to prevent the problems so to avoid fixing them afterwards, since problems are always costs.

■ The data sources

In our case, data are generated by the field devices – meters, sensors and I/Os – which are the sources to be used to implement an energy efficiency plan, a load monitoring solution or simply cost centers for cost allocations.

■ FDBB the Field Data Building Block

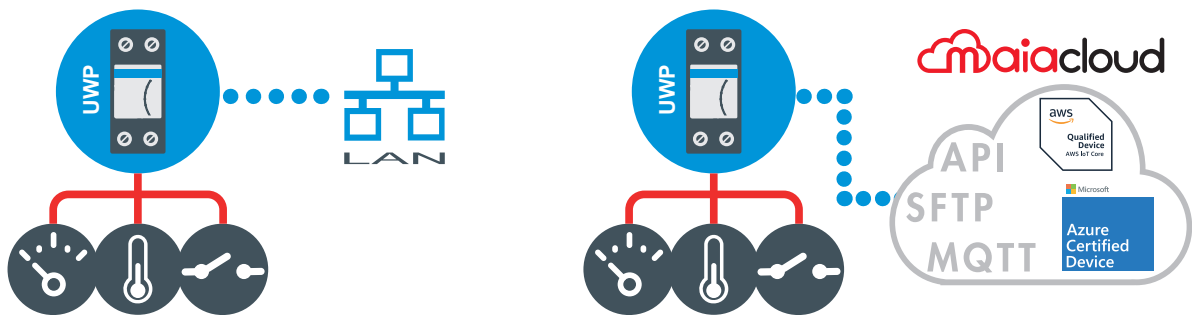

The fact that Carlo Gavazzi can provide field devices equipped with simple communication buses that can be connected to an UWP Web Platform is the core of the solution but also the prevention of problems.

If the field devices are aimed to generate data, the UWP Web Platform, through its field buses (wired Modbus and Dupline but also wireless) collects all data and manage them locally. Therefore, our ideal building block FDBB embeds the data generation and the edge computing as in the picture above.

■ The solution is to decentralise the monitoring system

By using FDBBs (Field Data Building Blocks) the system becomes scalable and in case of missing communication to either the PC or the Cloud where the management software is running, the single FDBBs will continue to work and to manage data locally. As soon as the communication will be back, Em²-Server will synchronize the data again and update its database.

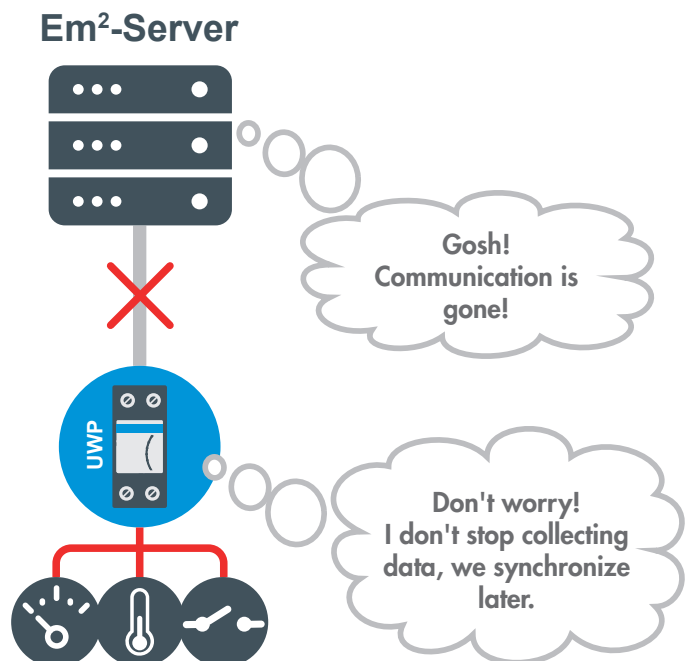

Data aggregation and standard web-browser access

Single-site or multi-site unique solution.

Em²-Server solution is scalable and therefore suitable to be used in small installations but also in large facilities or spread geographically in different locations in the same country or in different countries. It can scale up to 100 FDBBs which means up to 100 UWP Web Platforms and up to 3,200 Modbus meters. Em²-Server allows to aggregate information replicated by both UWP 3.0 SE and UWP 4.0 SE within a single centralized database and the relevant information may be accessed by users from wherever by using a standard web-browser.

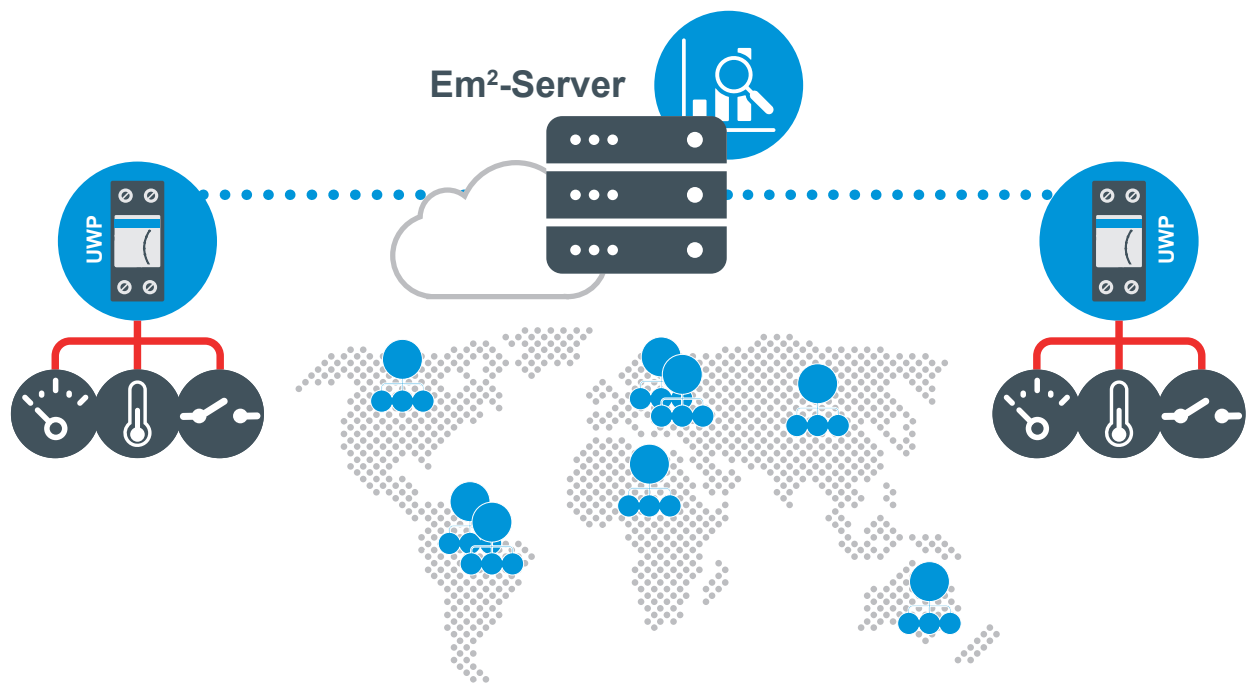

Em²-Server has:

- a multilingual Web based user interface
- user rights management
- concurrent access from multiple locations
- integrated MAP view and interactive mapping feature
- movable and resizable dashboards fitting the needs of a control room
- hierarchical tree to navigate data with ease
- Excel[®] reporting and PDF billing simulation

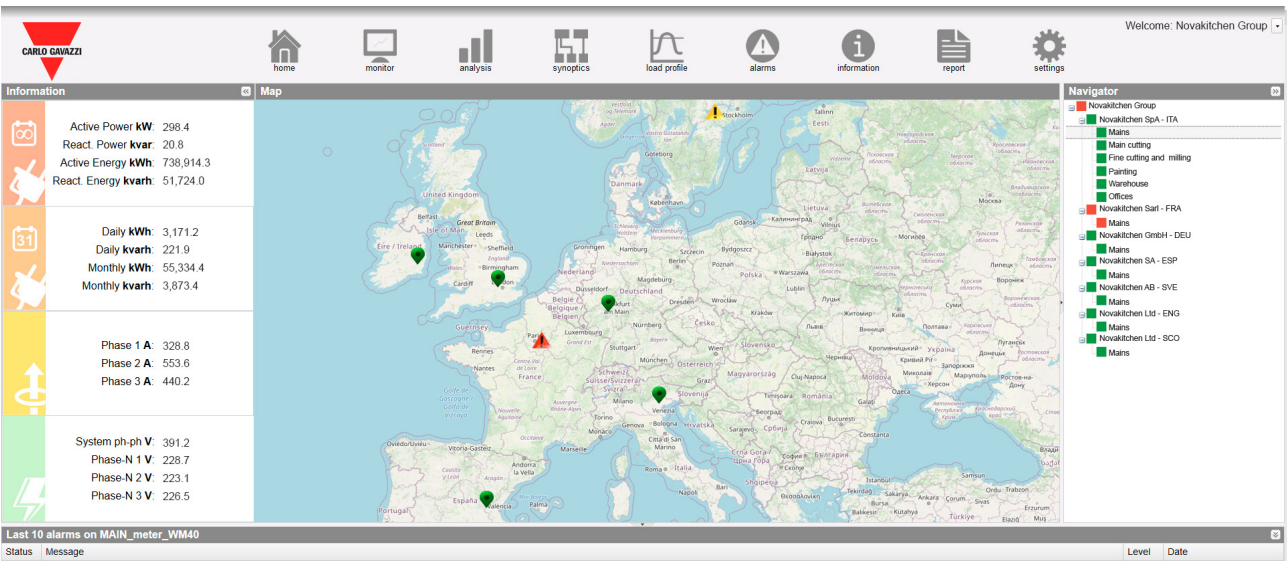

Monitoring

On premises and Cloud solutions

Energy cost centers and other cost analysis tools

Em²-Server is a multi-function solution which manages field-sensor data of any type.

Energy efficiency and cost allocation are important goals to achieve, being part of an OPEX (Operating Expenses) reduction strategy of a company. To understand how energy is consumed and where it can be saved, it is important to have specific tools and dashboards which allow to perform an adequate analysis.

It does not matter if the need is to know on time, energy data to perform a cost analysis or to sell energy services, Em²-Server provides you the tools you need. This solution may generate billing documents but may also produce a simulation of a monthly or yearly energy bill based on existing consumption and utility supplier vs. same consumptions but based on another utility supplier to evaluate the real convenience to change over.

Novakitchen SpA - ITA
Via Dell'energia, 8. Treviso (31100)
+39 041 355811

STATEMENT DATE
10/04/2020

AMOUNT DUE
41.440,6 €

BILLING PERIOD
01/01/2020
31/03/2020

SERVICE ADDRESS

CUSTOMER: Novakitchen SpA
Address, City, (Zip Code): Via Dell'energia, 8. Treviso (31100)
Email:
Phone Number: +39 041 355811

MEASUREMENT POINTS		
MEASUREMENT POINT	kWh consumption	kvarh consumption
Mains	166.003,2 kWh	11.620,2 kvarh
Main cutting	64.741,2 kWh	4.531,9 kvarh
Fine cutting and milling	41.500,8 kWh	2.905,1 kvarh
Painting	34.860,7 kWh	2.440,2 kvarh
Warehouse	14.940,3 kWh	1.045,8 kvarh
Offices	9.960,2 kWh	697,2 kvarh

CHARGES DETAILS	
COSTS	SUBTOTAL
kW amount	9.900,0 €
Main cutting	12.300,8 €
Fine cutting and milling	7.885,2 €
Painting	6.623,5 €
Warehouse	2.838,7 €
Offices	1.892,4 €
TOTAL CHARGES	
Total	41.440,6 €

Novakitchen SpA - ITA
Via Dell'energia, 8. Treviso (31100)
+39 041 355811

STATEMENT DATE
10/04/2020

AMOUNT DUE
47.813,5 €

SERVICE ADDRESS

CUSTOMER: Novakitchen SpA
Address, City, (Zip Code): Via Dell'energia, 8. Treviso (31100)
Email:
Phone Number: +39 041 355811

MEASUREMENT POINTS			
DATE	kWh READING	kvarh READING	
31/12/2019	6.457.342,7 kWh	452.014,0 kvarh	
31/01/2020	6.512.142,7 kWh	455.850,0 kvarh	
29/02/2020	6.563.771,5 kWh	459.464,0 kvarh	
31/03/2020	6.623.345,9 kWh	463.634,2 kvarh	

CHARGES DETAILS			
COSTS	QUANTITY	UNIT PRICE	SUBTOTAL
Active energy			
kW amount	990,0 kW	10,00 €	9.900,0 €
t1	145.619,2 kWh	0,19 €	28.073,9 €
t2	20.384,0 kWh	0,17 €	3.466,7 €
Total			41.440,6 €
Reactive energy			
t1	10.193,3 kvarh	0,60 €	6.116,0 €
t2	1.426,9 kvarh	0,18 €	256,8 €
Total			6.372,8 €
TOTAL CHARGES			
Total			47.813,5 €

So, Em²-Server embedded essential tools are capable to perform a budget, comparative or summarized into a billing simulation PDF file and monthly balance analysis. Moreover, data can be exported using powerful Excel[®] export embedded analysis tool.

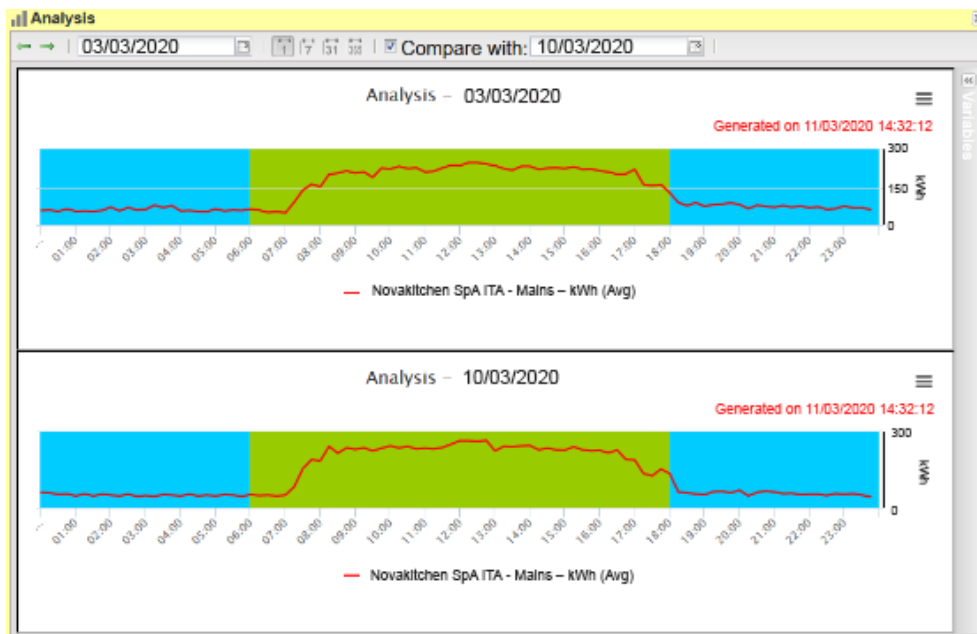

From cost analysis to advanced load profiling

Cost of energy in business activities is connected also to a tariff management.

Em²-Server manages multiple tariffs, multiple profiles, multiple calendars to make the entire analysis more accurate. This means, in a global business activity, to be able to manage automatically different energy costs in different geographical areas but also different working calendars at the same time producing, at the end, a common document.

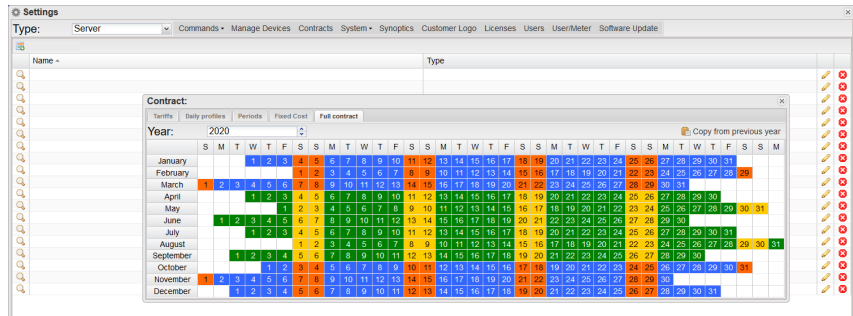

Advanced Load profile analysis

As important part of Em²-Server tools, there are also the specific load profile statistical (average, median, min, max, Sigma standard deviation) analysis which may based, on the set time, on hundreds of thousands of data and is aimed to discover at a glance, the load behaviour differences, thus discovering anomalies and suspicious consumptions.

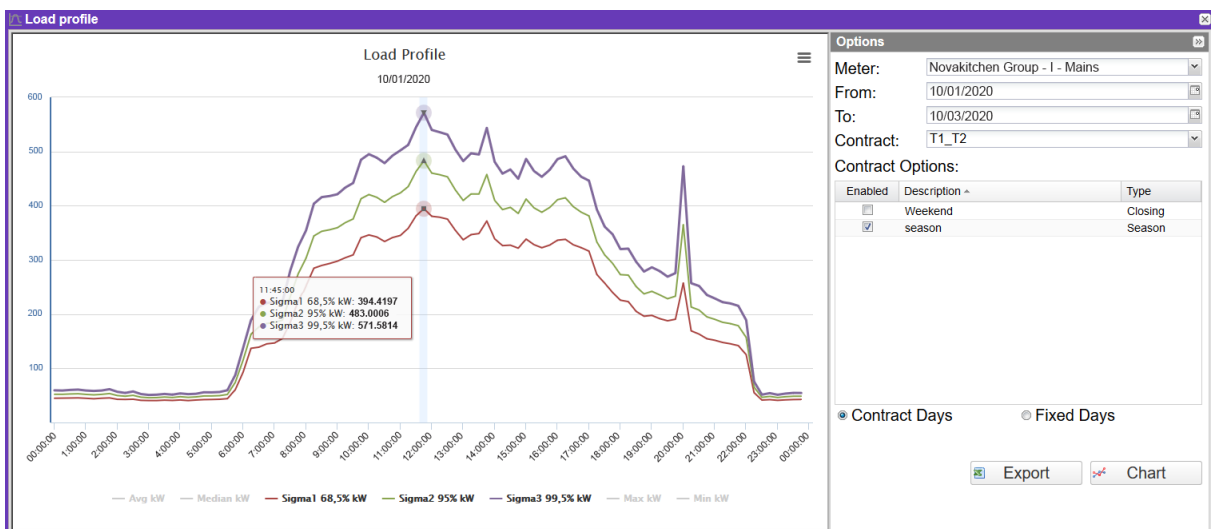
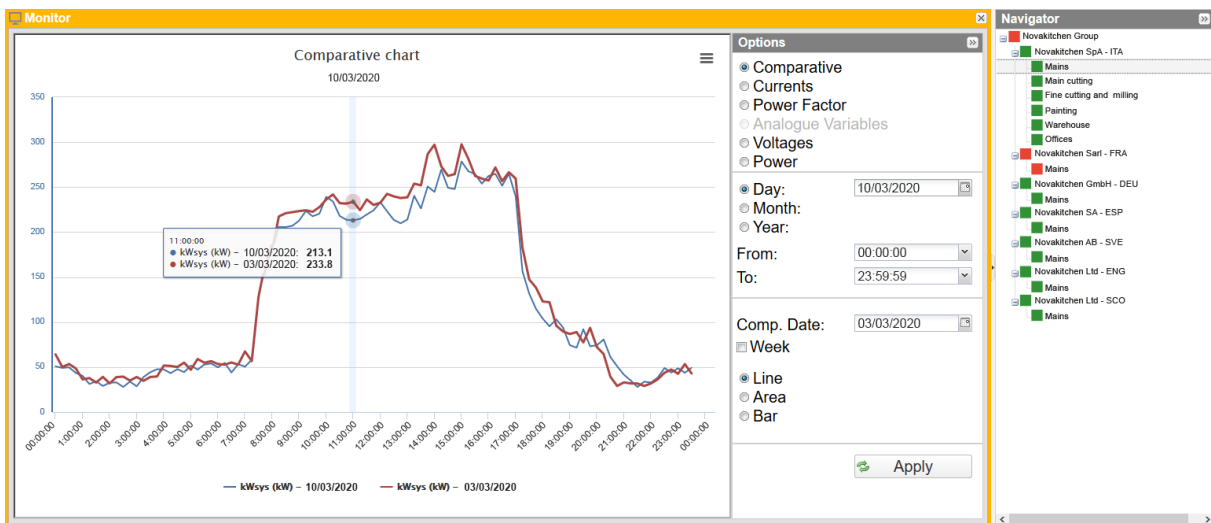

Monitoring

Long range wireless communication

The wireless technology

Choosing the right wireless technology is dependent on the application!

Gathering data in a secure, automatic and economic way is always difficult. There are a variety of different applications which may change according to the size of the meter network and of the area to be covered. Moreover, there are many available wireless communication technologies with some advantages, such as minimizing the wiring and installation costs also in case of retrofitting an existing installation, but also some limits, such as obstacles and interferences which may be fixed by skilled installers, and also cyber-security issues (if encryption is not carried out correctly). The "Range" graph below highlights, based on different technologies, the coverage distance, which can vary from just a few meters to global coverage using mobile communication.

However, the most popular wireless technologies are limited in terms of signal range or suffer from cost disadvantages, as they require a mobile phone contract for each measurement point. Moreover, in urban areas the situation is particularly complicated due to the restrictions of the rule concerning band occupation and interference with other devices. In all these cases the answer is LoRaWAN®, the long-range wireless communication technology.

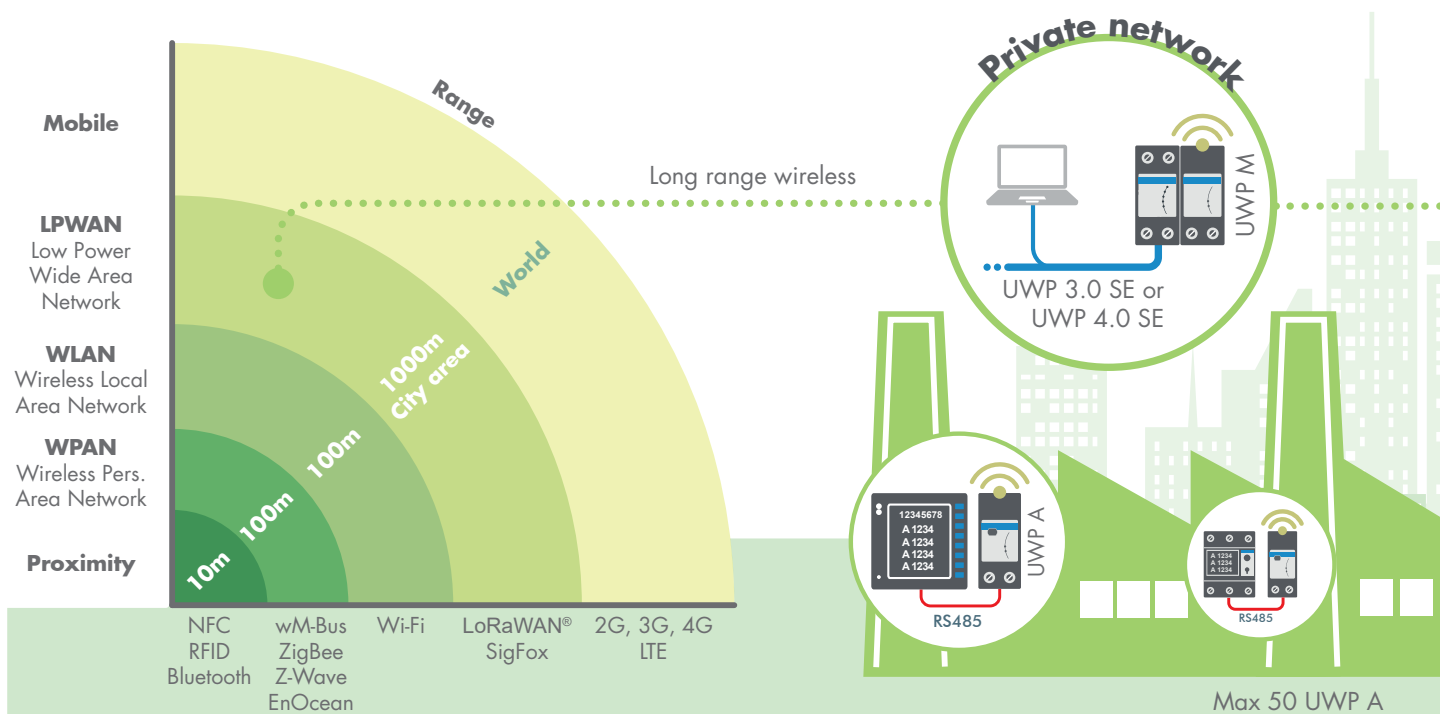

■ Long Range Communications or LoRaWAN® integration

Leveraging an existing standard LoRaWAN® network to send metering data to a remote system or creating from scratch a Long Range Wireless network in the license free band are both scenarios available to system integrators. In the former case UWP A converts meters into LoRaWAN® enabled IIoT units. In the latter, UWP A + UWP M + UWP (3.0 SE or 4.0 SE, depending on the size of the installation being managed), depending on the size of the installation being managed) are the 3 tiers of a complete energy monitoring system capable to cover wirelessly both dense urban/indoor regions and rural areas (up to 10 km range in open air, 1 km in typical applications).

■ Easy commissioning and diagnostics

Standardized set-up for connecting any LoRaWAN® gateway, or plug and play tools to build-up and maintain a system based on Carlo Gavazzi's UWP Web Platform, are the key factors to preserve users from headaches. Plug and play deployment of either small or large networks is possible for both private and public networks.

■ Security

UWP A and UWP M embed end-to-end AES128 encryption so to provide the necessary data security.

■ Low operating expenses

Wireless solution (EU 868MHz ISM band) with no SIM card or annual fees and a long communication range, allows users to deploy a wireless monitoring network from scratch by themselves.

■ Reliable communication

Long communication range, immunity to interferences and embedded security allow engineers and installers to build reliable wireless monitoring networks.

Private and Public network solutions

LoRaWAN®, the long range, fast configuration, easy commissioning, secure, competitive, and reliable communication solution.

Energy efficiency monitoring and cost allocation, sub-metering in large buildings, industry, energy farms and cities are the best examples for long range wireless Carlo Gavazzi solutions. Thanks to LoRaWAN® long communication range, security and robustness, wireless networks can be easily set-up, without the high expense associated with the use of SIM cards or repeaters.

Whenever the user deals with a project focused on sub-metering, cost allocation, or the energy efficiency monitoring realm, the need for minimizing the TCO (total cost of ownership) is always a consideration. The long-range wireless solution of Carlo Gavazzi simplifies this scenario.

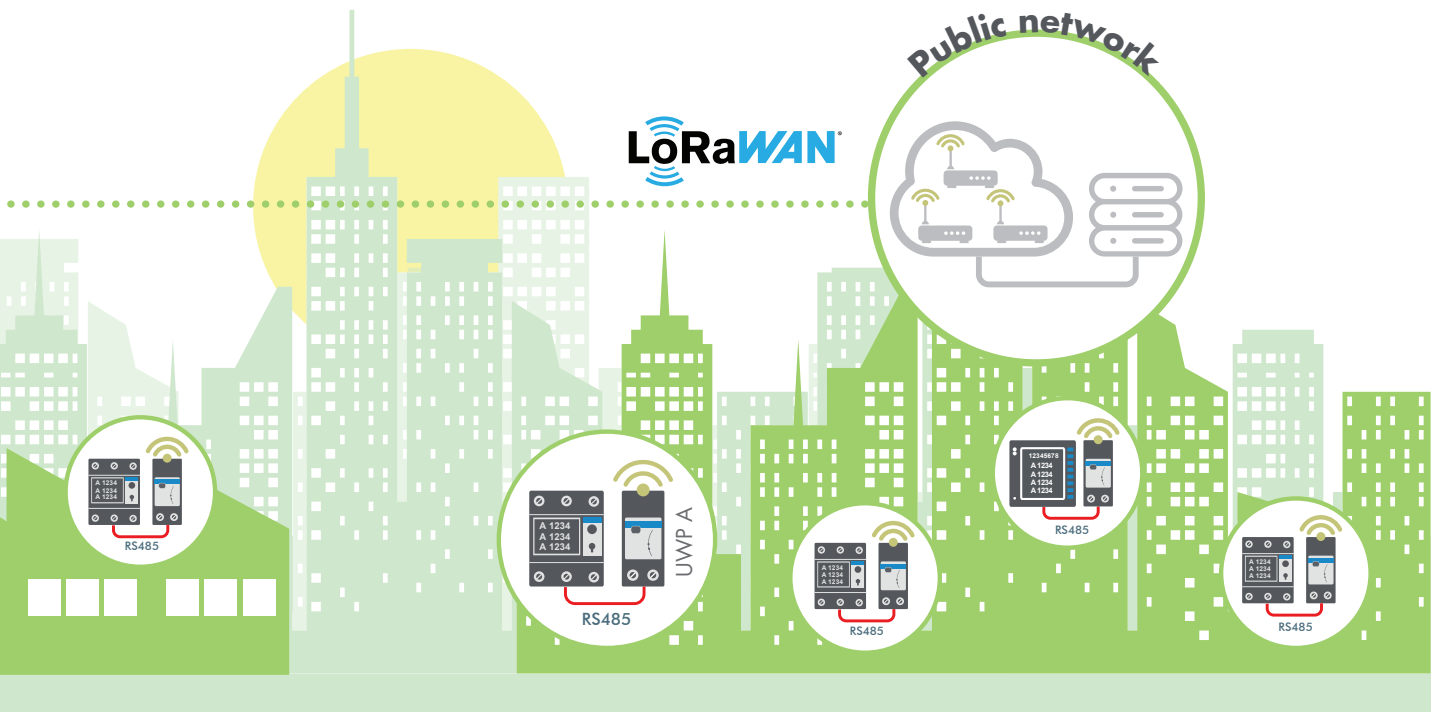

UWP M

- Comprehensive energy monitoring solution
- Wireless solution with no SIM card (ISM band)
- Data concentrator for up to 50 UWP A endpoints for each UWP M
- Communication range: up to 10 km in open air
- Fast commissioning
- Robust and secure communication
- Integrated into either UWP 3.0 SE or UWP 4.0 SE ecosystem
- Power supply from either UWP 3.0 SE or UWP 4.0 SE auxiliary bus



UWP A

- LoRaWAN® adapter for Carlo Gavazzi meters
- Communication range: 10 km in open air, 1 km in typical applications
- USB port for easy set-up via UCS Software
- Universal power supply (19 – 29 V dc and 115 – 240 V ac)
- Configurable LoRaWAN® communication
- OTAA or ABP authentication
- Communication interval from 5 min to 24 h
- Plug and play integration into either UWP 3.0 SE or UWP 4.0 SE ecosystem via UWP M



UCS freeware software

- Easy deployment of UWP A based wireless networks
- Configuration of any Carlo Gavazzi meter/analyzer
- Diagnostic functions

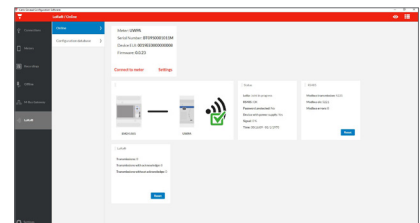

Monitoring

Panel mount meters

The evolution of user needs

The use of analogue panel meters is not only linked to cost reasons

Even today, analogue ammeters and voltmeters are frequently installed in distribution boards. The choice is almost always dictated not only by cost reasons, but by the need to make any anomalies visible at a glance. The maintenance personnel in fact need to have immediate feedback on the main operating parameters in order to operate in optimal conditions both in routine and emergency situations.

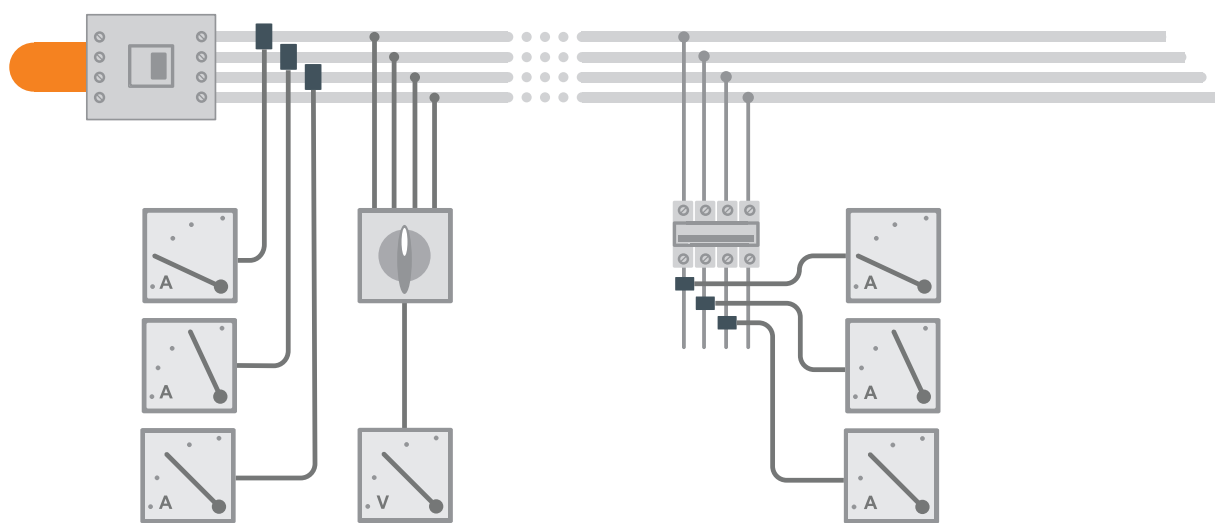

Users' needs change and with them the technical solutions proposed

The position of the pointer in the analogue scale and the comparison among other analogue panel meters on the same distribution board is preferred for the reduced effort of the user in processing the information he is voluntarily searching for (intrinsic cognitive load). But we know that the world evolves, becoming more complex and demanding. The ideal answer to this change is to offer a solution that allows an analogue comparative displaying, allowing a rough but immediate understanding of the variable being measured but also, by means of a digital display, a proper accurate visualization of the same variable.

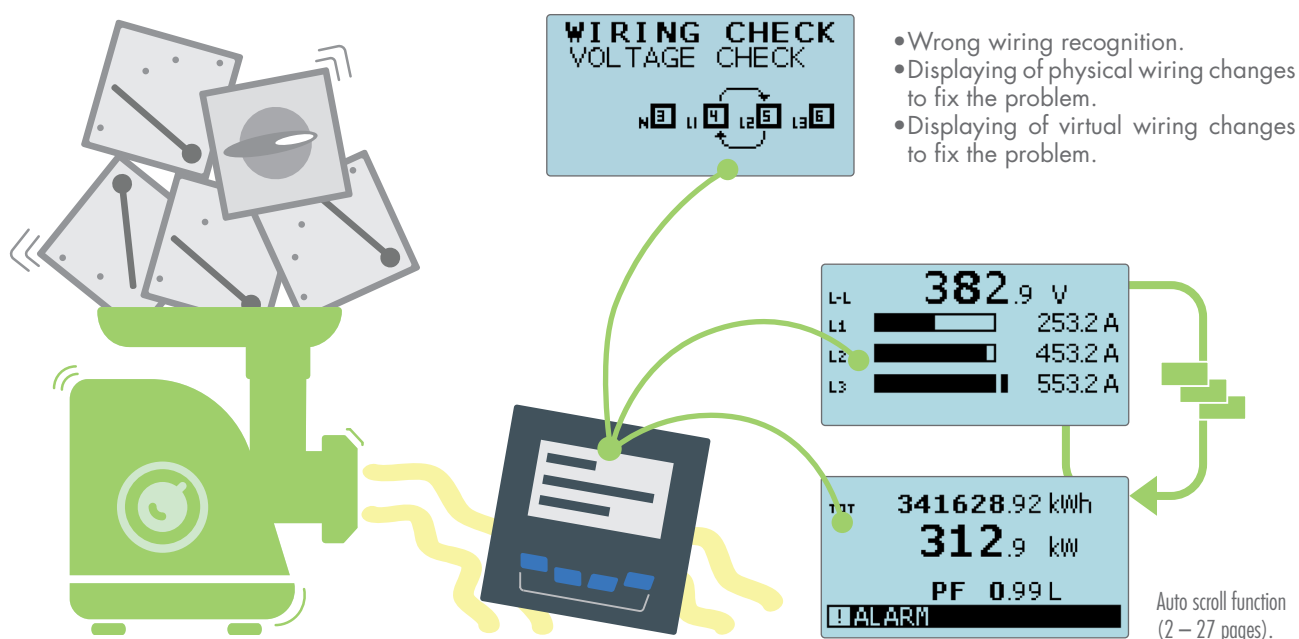

Immediacy of visualisation and integration

The answer to the traditional use of analogue panel meters is WM15.

WM15 is also the answer to the growing need for additional electrical variables to make more in-depth analysis. This solution condenses the information of four analogue panel meters into a single meter, but also provides an accurate measurement of power and energy thanks to the continuous and simultaneous sampling of all phases. When it is installed on a distribution board or on a machine, it can relate the energy consumption to the time the load is operating. Moreover, if an alarm is set, it can display it locally and transmit automatically and remotely all needed variables to validate the implemented energy efficiency policies or provide data to start a preventive maintenance plan instead.

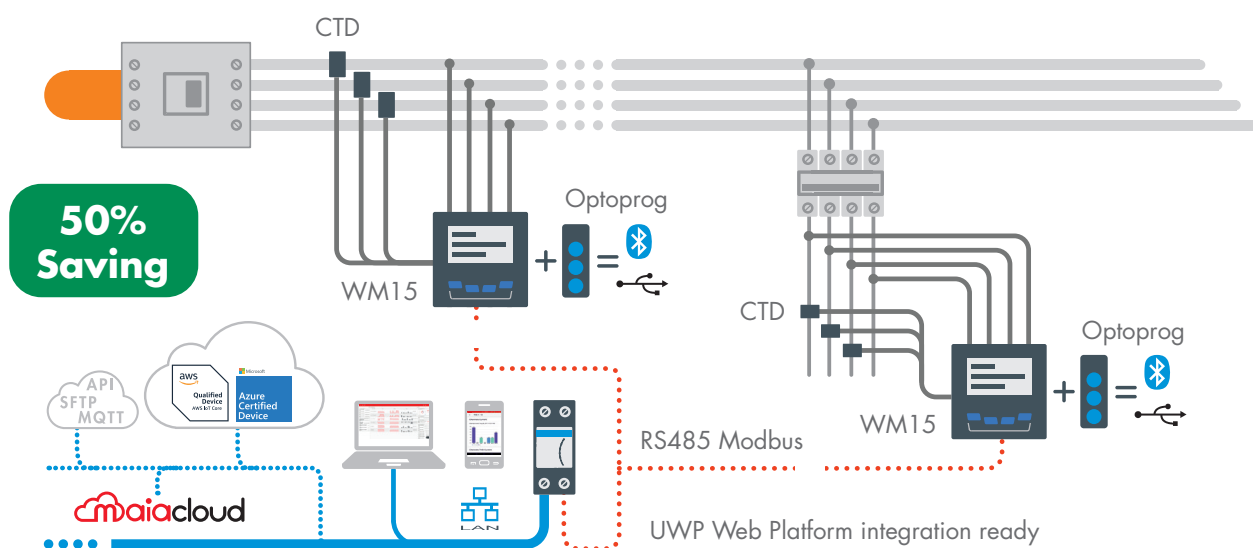

How to reduce installation and commissioning costs

Installation and commissioning of advanced panel meters often have additional and hidden costs compared to standard analogue panel meters. WM15 reduces these costs by 50% compared to a standard 4 analogue meters installation and even more versus a standard power analyser installation thanks to its advanced wiring-control algorithm and its improved usability.

The additional benefits of OptoProg and UCS in both installation and commissioning costs reduction

- The installer can check the connections and quickly change the configuration parameters using a smartphone connected via Bluetooth to OptoProg.
- The panel builder, in case of a series production of panels, can easily replicate the same configuration on all WM15 units with a single command speeding up the production process.
- In case of wiring errors, UCS provides a diagnostics of the problem encountered and can virtually correct the proper phase associations between voltages and currents so to fix the error without requiring a second intervention.

WM15

- 5 A current inputs for current transformers
- Up to 477 V L-L measuring inputs (self-power supply)
- Up to 690 V L-L measuring inputs (auxiliary power supply 120 - 240 V ac/dc)
- 96*96 panel mounting, 59 mm depth
- 4*4-DGT + 3-bargraph backlit matrix display
- Bidirectional kWh and kvarh, run hour meter
- System and phase: V L-L/L-N, A, W, var, VA, PF, Hz, THD (V-A)
- Current and power demand calculation
- Static output for pulse transmission or alarm
- RS485 Modbus RTU port (100 ms data refresh)
- Basic accuracy (V/A): $\pm 0.5\%$ RDG, kWh class 1 (IEC/EN 62053-21)
- MID approved (on request)



Monitoring Beyond panel mount meters

Modular main metering with power analysis

A high-spec meter is often time demanding due to its installation and commissioning complexity: how can you make it time and cost effective?

Yes, by selecting the most appropriate device to meet the different installation and application needs among the three available power analyser models. Metering capabilities, and control functions, as well as a common modular system are the key features. Panel Builders, System Integrators and Installers enhance and speed up their activities of initial meter configuration, communication diagnostics and commissioning with the help of the combination of new and innovative tools like OptoProg, UCS desktop, and UCS mobile.

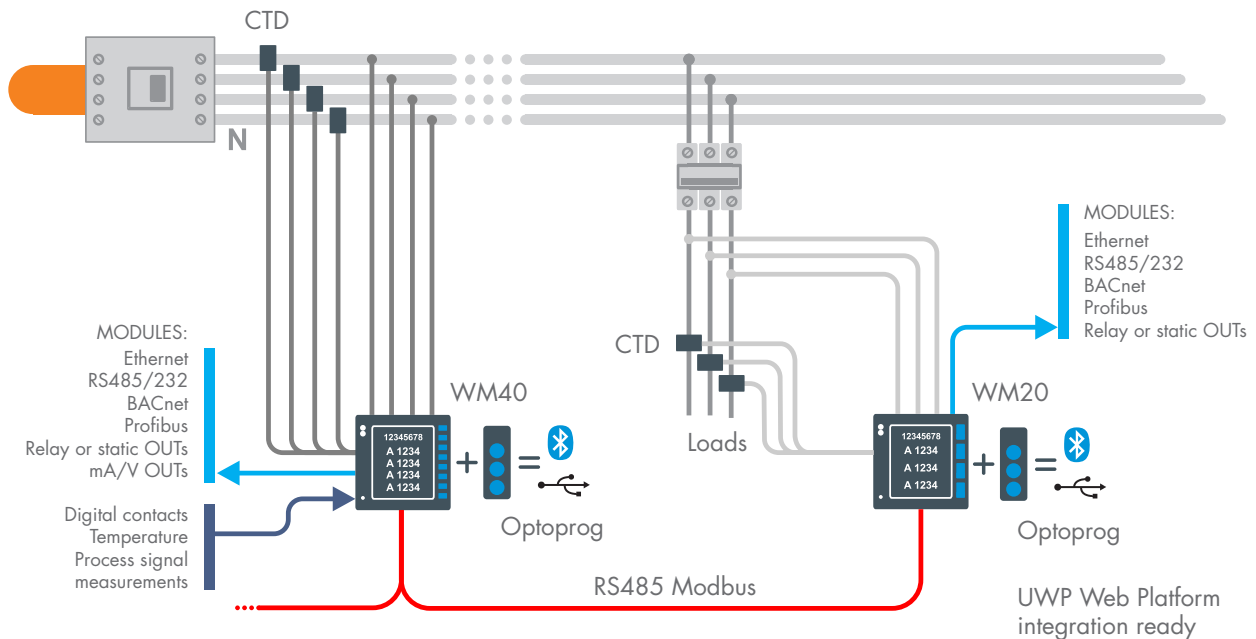

WM20

- 96*96 mm panel mounting housing with front protection degree IP65
- 5 A current inputs for current transformers
 - Up to 793 V L-L measuring inputs
 - Basic accuracy (V/A): $\pm 0.2\%$ RDG
- Single and three-phase measurements: V, A, An, Hz, PF, W, VA, var, run-hour, kvarh, bi-directional kWh (cl. 0.5s IEC/EN62053-22)
 - 9+1-DGT counter variables, backlit LCD display
 - Modular housing (see the modules list besides)
 - Optical port for fast data reading and configuration
 - Universal power supply (90 - 264 V ac/dc, 21 - 55 V ac/dc)
- THD analysis up to 31st harmonics with source detection, single harmonics via Modbus
- 3*4 DGT instantaneous variables, LCD display
- Max values of all power variables
- Automatic scrolling pages
- 2 freely configurable virtual alarms

WM30

- 4*4 DGT instantaneous variables, LCD display
- Avg and max values of all system and single phase variables
- 4 freely configurable virtual alarms
- Real time clock
- Other features, same as WM20

WM40

- 4-tariff management
- Factor K and TDD metering
- 16-alarm PLC logic and digital inputs for utility metering, built-in event and data stamping for instantaneous variables and load profiling
- Other features, same as WM30

Modules

WM20/WM30/WM40

- RS485/RS232 Modbus RTU
- BACnet IP
- BACnet MS/TP
- Ethernet (Modbus TCP)
- EtherNet/IP (WM20 excluded)
- Profibus DP-VO
- 2-static and relay outputs
- 2*20 mA dc or 2*10 V dc outputs
- 2*20 mA dc or 2*10 V dc outputs
- Up to 4*20 mA dc or 10 V dc outputs
- 6-channel digital inputs, up to 6 relay/8 static outputs + OR/AND alarm logic management
- Direct An + Temperature + Process signal measurements

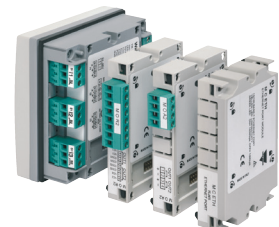

Advanced configuration and commissioning tools

An innovative solution to drastically reduce both configuration and commissioning time!

The installation, the configuration, and the commissioning of a power analyser has an intrinsic complexity which is due not only to the product itself, but also to the sequence of events which usually starts in the workshop of a Panel Builder and moves to the plant for the final installation. Hence, one product, which for different reasons and in different contexts moves through different professionals. To be able to be effective, there is the need to be able to supply a tool matching the skills and needs of different people. OptoProg, with its App, or simply as desktop software, is the best answer to simplify the whole process.

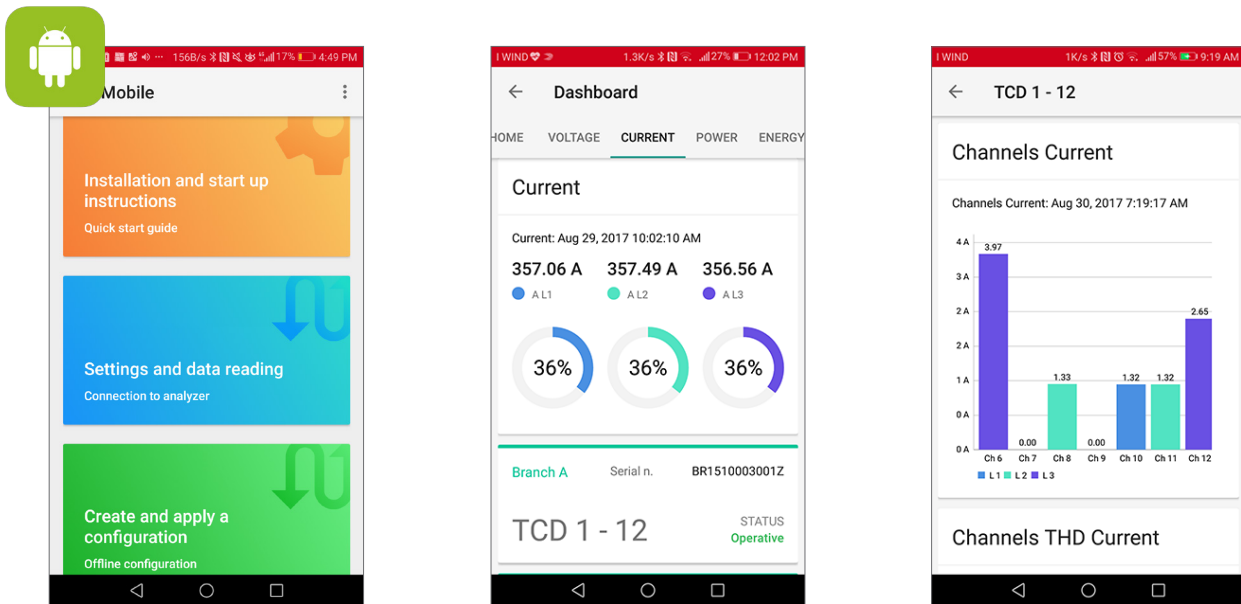

How do you do it? OptoProg + UCS is the solution!

OptoProg, the optical port-based coupling unit with built-in rechargeable battery, provided with both USB and Bluetooth communication capabilities to be used in combination with either UCS desktop or UCS Mobile (Android), with its excellent usability, allows the Panel Builder to set all initial metering parameters without physically using the meter front keypad. If the panel is produced in series with the same overall characteristics and meter settings, by using the configuration upload and download function, the process is further shortened and error free. Once the distribution board with the power analyser is on site, the System Integrator using its OptoProg unit and UCS software can download the meter configuration parameters, change them, add alarms and upload the new configuration to the power analyser again to complete the process. With the same UCS it is possible to test the communication to other devices in the same Modbus network. The whole OptoProg process can be performed without opening the distribution board door, making this process more efficient, effective and safe. Once everything is done, just remove OptoProg from the power analyser and install it on another meter.

OptoProg

- Bridge mode use with embedded optical port
- Built-in lithium battery for one month operations
- Sleep mode for energy savings
- Configuration and communication status LED
- Bluetooth 2.0, 2.1, 3.0 and 4.0 connectivity
- Micro-USB B port
- RED 2014/53/EU, FCC and IC approvals



Optoprogram is compatible with:
WM15, WM20, WM30, WM40, WM50. ET112, ET330, ET340.

Monitoring

Current adapters and quick-fit solutions

Solid-core and split-core current adapters

From compact sizes to high currents and from solid-core to split-core, these are the current adapters for Carlo Gavazzi meters and the appropriate solution for any kind of installation.

TAD K/K2

TAD	from (A)	to (A)
K	1	40
K2	1	250

- Wound primary/fixed bar
- Secondary: 5 A (standard), 1 A (available upon request)
- Sealable terminal covers
- IEC/EN61869-2 compliant

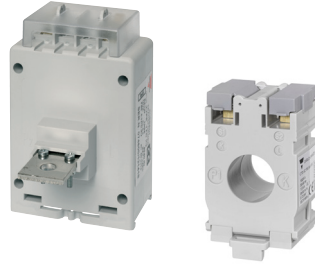

CTD 1Z

CTD	from (A)	to (A)
1z	50	200

- Solid core for cable or bus-bar
- Cable diameter: 22 mm
- Secondary: 5 A
- IEC/EN 61869-2 compliant

CTD 1/2/3/4-X

CTD	from (A)	to (A)
1x	50	300
2x	40	600
3x	50	800
4x	150	1600

- Solid core for cable or bus-bar
- Cable diameter: 23 mm to 51 mm
- Bus-Bar: 20*5mm to 64*20 mm or 51*43 mm
- Secondary: 5 A (standard), 1 A (available upon request)
- Sealable terminal covers
- IEC/EN61869-2 compliant

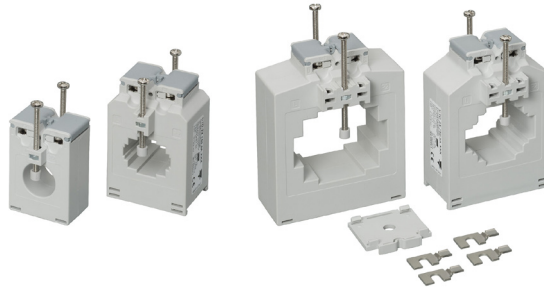

CTD 8/9/10/11/12-V-H

CTD	from (A)	to (A)
8 V/H	150	1600
9 V/H	400	2500
10 V/H		3200
11 V/H	1000	4000
12 V/H	1000	4000

- Solid core for cable or bus-bar
- Bus-Bar: 37*125 mm to 53*125 mm
- Secondary: 5 A (standard), 1 A (available upon request)
- Sealable terminal covers
- IEC/EN61869-2 compliant

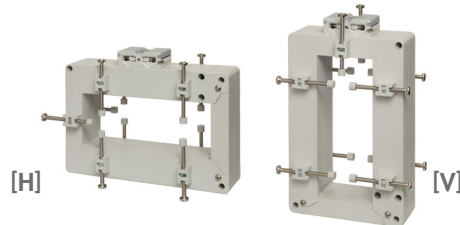

CTD 5/6-S

CTD	from (A)	to (A)
5 S	100	400
6 S	150	1000

- Split-core for cable or bus-bar
- Bus-Bar: 26*32 mm, 50*52 mm
- Secondary: 5A (standard), 1 A (available upon request)
- Sealable terminal covers
- IEC/EN61869-2 compliant



CTD 8/9/10-S

CTD	from (A)	to (A)
8 S	150	1600
9 S	400	2500
10 S		3200

- Split-core for cable or bus-bar
- Bus-Bar: 31*81 mm to 50*125 mm
- Secondary: 5 A (standard), 1 A (available upon request)
- Sealable terminal covers
- IEC/EN61869-2 compliant

CTA 5/6

CTA	from (A)	to (A)
5 X	100	300
6 X	200	600

- Split-core for cable
- Secondary: 5 A
- Cable diameter: 24 mm (5x), 36 mm (6X)
- IEC/EN61869-2 compliant



Main and sub-metering for new installations

Quick-fit solutions.

When installation time, meter configuration, and commissioning are a concern, Carlo Gavazzi Quick-fit is the solution. In a typical installation (lighting, HVAC, heating, refrigeration) using 1+4 regular meters you can achieve a time reduction of about 70% using 3 quick-fit meters instead.

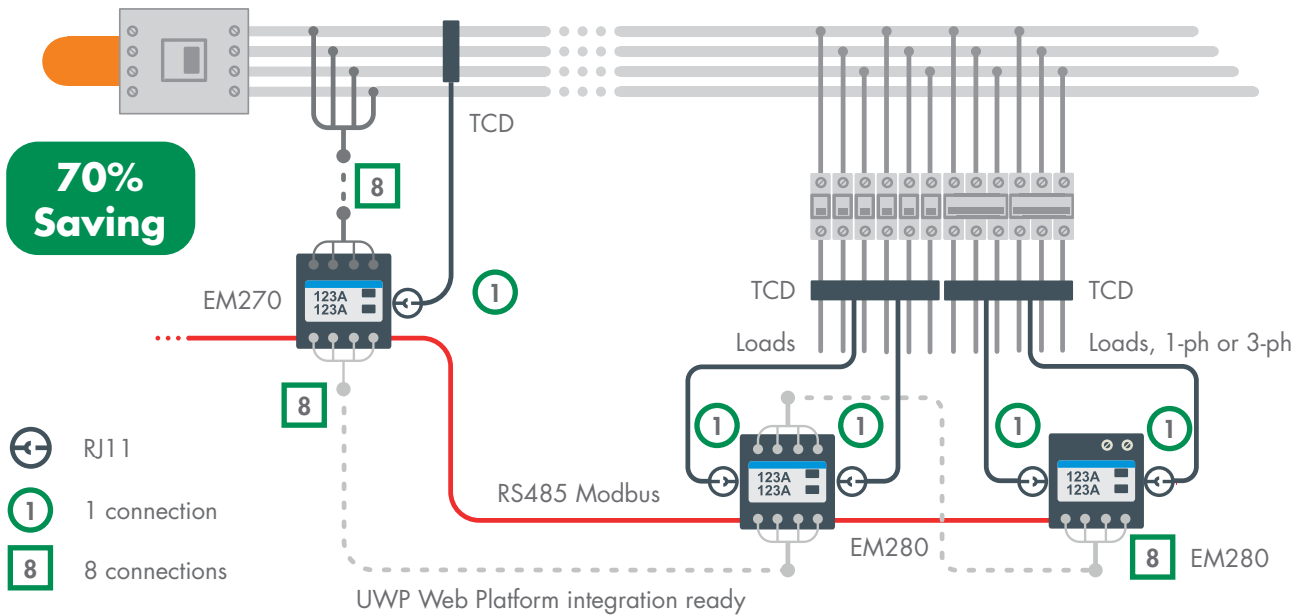

EM270, main metering solution

- Patented meter, 4-DIN and 72*72 mm solution in the same housing for DIN-rail or panel mounting. Detachable 3*3-DGT/7-DGT display
- Up to 456 V L-L ac and TCD-based current measuring inputs
- Current measurement by two triple solid-core sensing units with quick RJ11 plugs (see TCD X series)
- Quick configuration by automatic recognition of TCD units
- 2*3-phase energy analysers with sum function in the same unit
- Measurements: V, A, Hz, PF, W, VA, var, bi-directional kWh
- Basic accuracy (kW): $\pm 1.25\%$ RDG (meter + TCD x unit). kWh: class 1 (IEC/EN 62053-21)
- RS485 Modbus RTU. 2 pulse outputs (loads 1 and 2)
- Self powered (230 V ac)

TCD 1X-2X-3X, sensing solutions

- Triple solid-core current sensing unit

Model	Primary (A)	Bus-bar sizes (mm)	Centre-to-centre distance (mm)
TCD 1X	3*160	15.5*25	25
TCD 2X	3*250	21*25	35
TCD 3X	3*630	31*31	45

EM280, sub metering solution

- Patented meter, 4-DIN and 72*72 mm solution in the same housing for DIN-rail or panel mounting. Detachable 3*3-DGT/7-DGT display
- Up to 456 V L-L ac and TCD-based current measuring inputs
- Current measurement by one 6-channel solid-core sensing unit with quick RJ11 plugs (see TCD 06 series)
- Quick configuration by automatic recognition of TCD units
- 2*3-phase/6*1-phase energy analysers with sum function in the same unit
- Measurements: V, A, Hz, PF, W, VA, var, kWh
- Basic accuracy (kW): $\pm 1.25\%$ RDG (meter + TCD-06 unit). kWh: class 1 (IEC/EN 62053-21)
- RS485 Modbus RTU. 2 pulse outputs (loads 1 and 2)
- Self powered (230 V ac)

TCD 06BX-06BS, sensing solutions

New installation, TCD 06BX	Retrofitting, TCD 06BS
6-channel solid-core current sensing unit	6-channel split-core current sensing unit
<ul style="list-style-type: none"> • Primary: 6*32 A, hole size: 7 mm. Centre-to-centre distance: 17.5 mm. RJ11 cable length: 80, 150 or 200 cm 	



Up to 630A

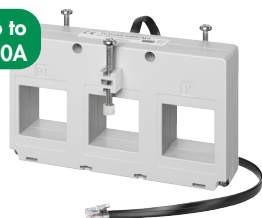

32A

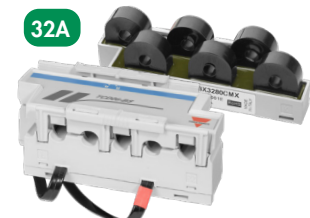

Monitoring

A compact range of DIN rail mount meters

Main and sub-metering for new installations

Full energy analysis capability and MID approval.

This range offers you both CT connection inputs and direct connection capabilities. EM24, EM100 and EM500 series can be provided also with MID (Measuring Instruments Directive 2014/32/UE) approval for fiscal metering (only for the European market). The three key features of this offer are: housing compactness – they can fit wherever you have a minimal space and display data completeness with 0.001 energy resolution – most important variable information available at a glance; full electric variables set availability also through the communication port – capability to know the single load behaviour so to perform a concise analysis. In addition, the EM500 series provides, based on Carlo Gavazzi's long design and application expertise, the best meter configuration and installation experience.

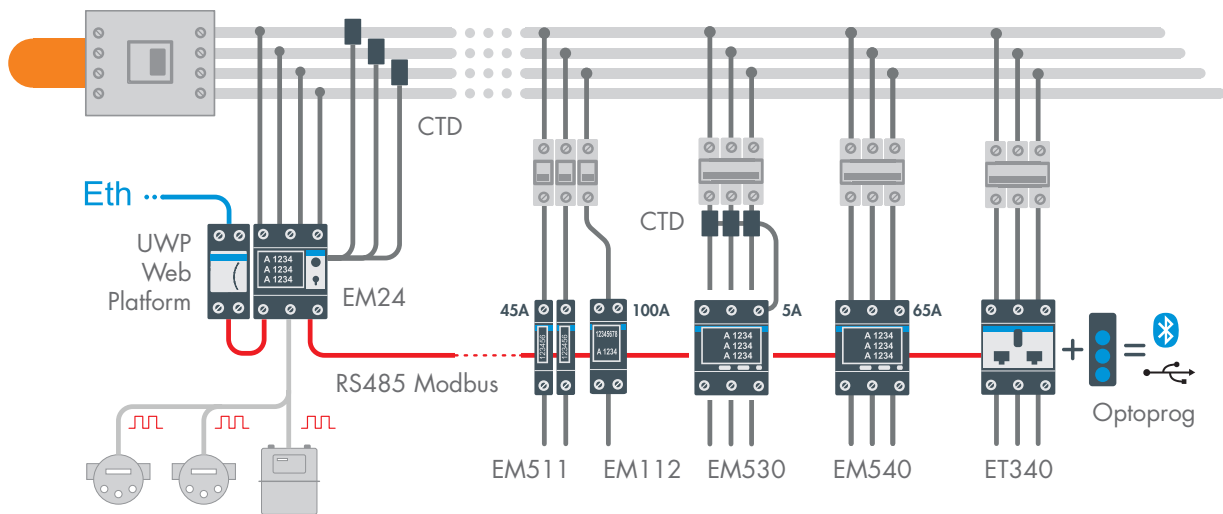

EM24, EM24 W1

EM24 and EM24 W1

- CT 5 A, 230 – 400 V L-L ac measuring inputs, 115 – 230 V ac power supply
- 65 A, 230 – 400 V L-L ac measuring inputs, self-power supply
- 4-DIN modules housing
- 3 counter digital inputs
- 2*8-digit LCD
- Single and three-phase measurements: V, A, Hz, PF, W, VA, var, run-hour, kvarh, 4-tariff, 3*1-phase kWh
- Basic accuracy (V/A): $\pm 0.5\%$ RDG
- Bi-directional kWh (cl. B EN50470-3 MID approved)
- Pulse output or RS485 Modbus RTU, M-Bus port or Ethernet

EM24 W1

- wM-Bus wireless communication
- Two antenna options: external or built-in

EM511, EM112

EM511

- 45 A, 115 -230V ac measuring inputs, 1-DIN module housing
- 6-digit + 3 decimals LCD
- digital input for tariff management and partial meter: start/pause/reset
- V THD and A THD up to 15th harmonics

EM112

- 100A, 115 -230V ac measuring inputs, 2-DIN modules housing, display backup by supercapacitor
- 8-digit backlit touch LCD

EM112 and EM511

- Basic accuracy (V/A): $\pm 0.5\%$ RDG
- Self powered
- Measurements: V, A, Hz, PF, W, VA, var, run-hour, kvarh, dual tariff
- Bi-directional kWh
- cl. B EN50470-3 MID approved
- Pulse output or RS485 Modbus RTU or M-Bus port

EM530, EM540

EM530

- CT 5 A, self powered
- Basic accuracy (V/A): $\pm 0.25\%$ RDG
- Bi-directional kWh: cl. 0.5S (IEC62053-22)

EM540

- 65 A, self powered
- Basic accuracy (V/A): $\pm 0.5\%$ RDG
- 3-DIN modules housing
- Backlit 11-digit + 2*10-digit LCD
- 230 – 400 V L-L ac measuring inputs
- Single and three-phase measurements: V, A, Hz, PF, W, VA, var, run-hour, kvarh, kWh, dual tariff, 3*1-phase kWh
- THD analysis up to 15th harmonics by current and voltage
- Bi-directional kWh (cl. B EN50470-3 MID approved)
- Pulse/Alarm output or RS485 Modbus RTU or M-Bus port

ET112, ET330/ET340

ET112

- 100 A, 115 – 230 V ac measuring inputs, 2-DIN modules housing

ET330

- CT 5 A, 230 – 400 V L-L ac measuring inputs, 90 V to 260 V ac/dc auxiliary power supply, 3-DIN modules housing

ET340

- 65 A, 230 – 400 V L-L ac measuring inputs, 3-DIN modules housing
- Single and three-phase measurements: V, A, Hz, PF, W, VA, var, run-hour, kvarh, dual tariff, 3*1-phase kWh, An
- Basic accuracy (V/A): $\pm 0.5\%$ RDG
- ET330 only: kWh class 0.5S (IEC62053-22)
- Self powered (230 V ac)
- RS485 Modbus RTU port (RJ45 daisy chain and screw terminal block connections)



The universal configuration software

UCS, the universal configuration tool continuously upgraded and compatible with all Carlo Gavazzi meters.

In addition to the standard display of variables, functionality and configuration parameters, it is common the need to be more effective and efficient during first meter configuration (by the Panel Builder) and site commissioning (by the System Integrator). UCS, the Universal Configuration Software, is the answer, providing a full set of effective tools for meter configuration, variable displaying and communication diagnostics. These tools are aimed to be quick and to help the different professionals, such as Panel Builder, Installer, System Integrator, and End-user, to limit and fix any installation, configuration, and commissioning error.

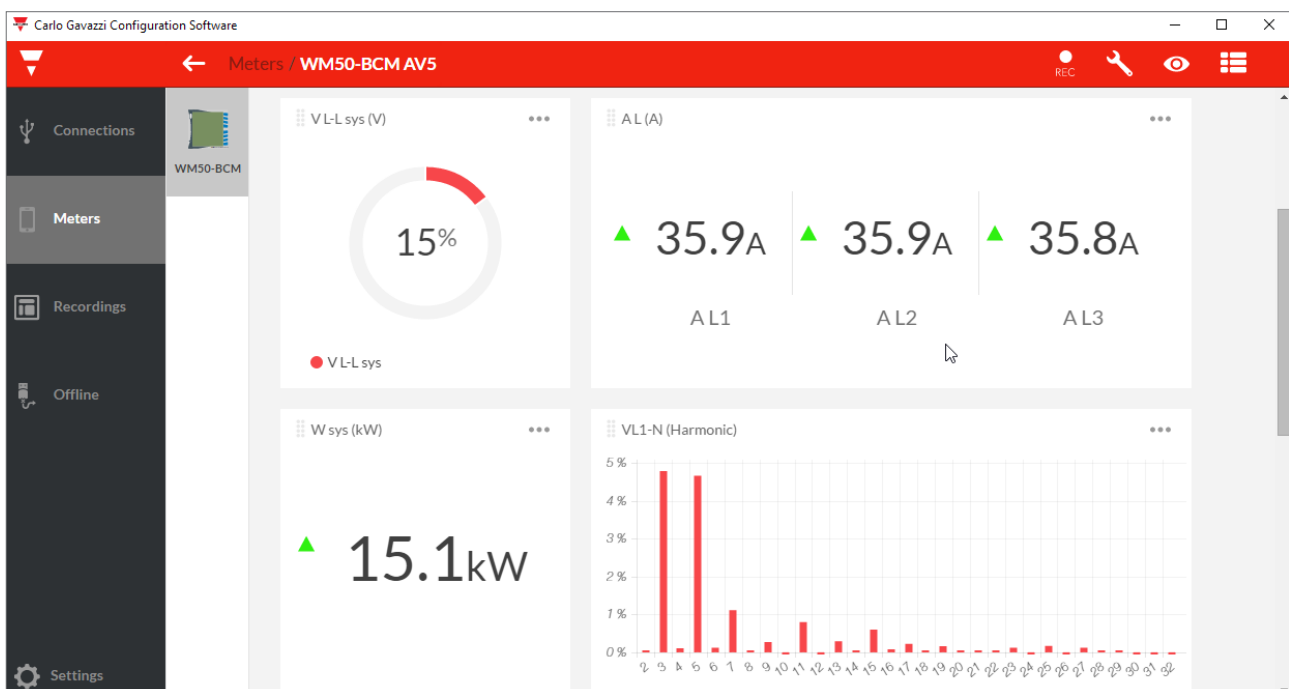
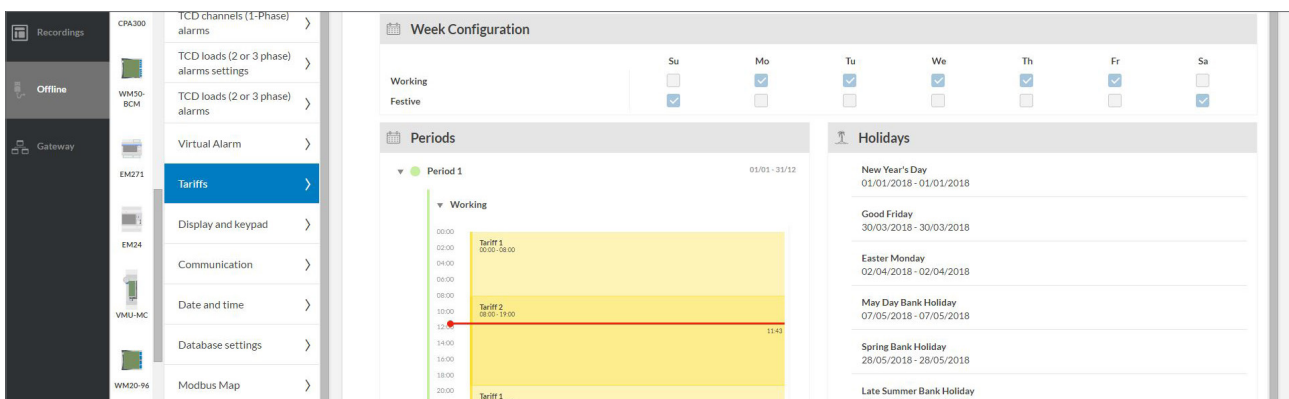
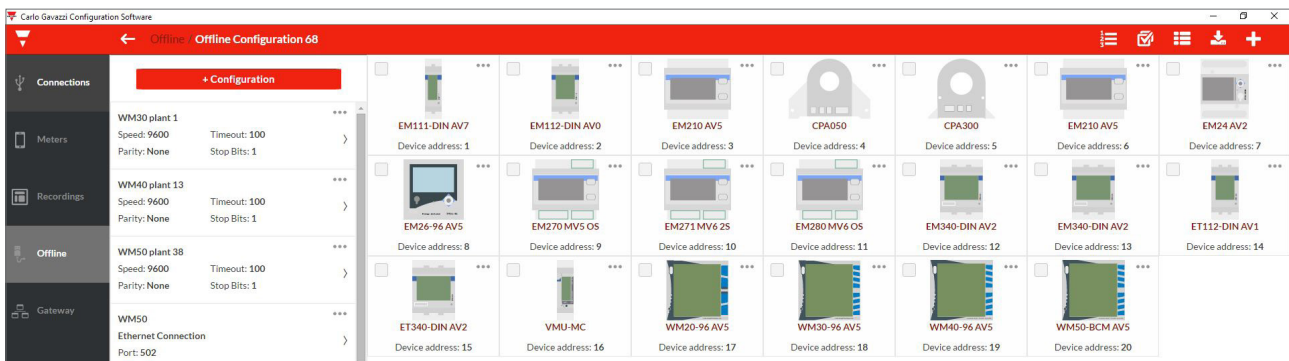

Monitoring

Quick-fit high-density metering solution

Distribution board-based solution

In a single solution the combination of a three-phase main meter with CT inputs and 65A integrated TCD sub-meter units with up to 96 single-phase channels or 32 three-phase channels.

When the electrical system is different from a bus-bar trunking or bus-duct system, and numerous loads are fed from a common distribution board, than WM50-96 is the ideal solution for branch circuit monitoring. The solution is based on one core unit WM50, which is usually installed and connected on the mains, and some TCD12 units as combined meters installed downstream the MCBs for single phase or three-phase loads. As the whole installation cost derives not only from the cost of the components, but even more by installation savings and commissioning costs, this innovative solution allows you to achieve more than 75% installation and commissioning savings vs. standard solutions.

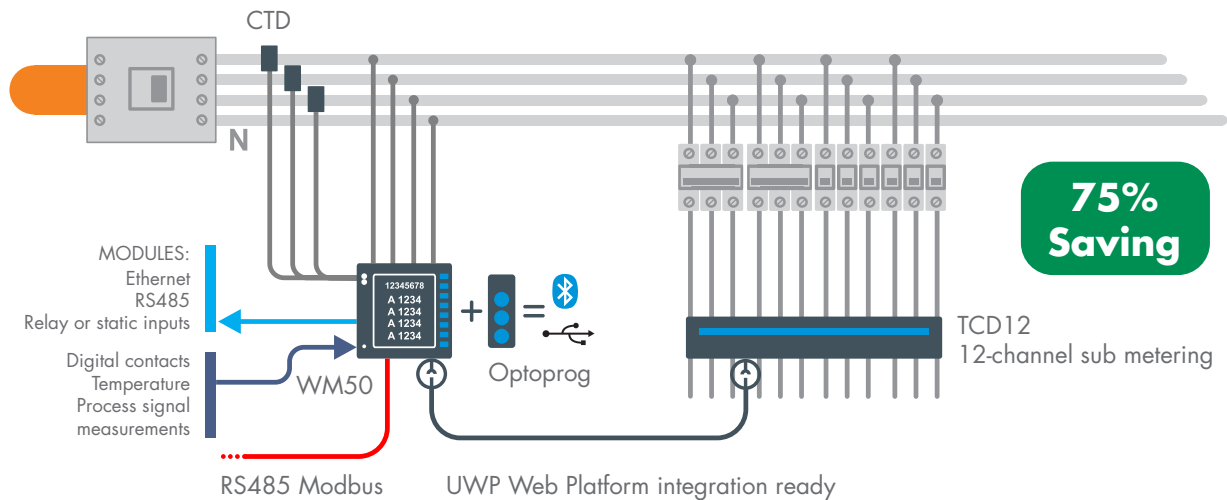

WM50, main metering solution for distribution boards

- 96*96 mm panel mounting meter with IP65 front protection degree and modular housing
- Up to 480 V L-L ac and 5 A CT measuring inputs
- Single and three-phase measurements: V, A, An, Hz, PF, W, VA, var, run-hour, kvarh, bi-directional kWh (cl. 0.5S IEC/EN62053-22), THD analysis up to 31st harmonics, single harmonics via Modbus
- Basic accuracy (V/A): $\pm 0.2\%$ RDG
- 9+1-DGT totalized and 4-DGT instantaneous variables LCD display
- Optical port for fast data reading and configuration
- Universal power supply (90 – 260 V ac/dc)
- 4-tariff management
- 16-alarm PLC logic and digital inputs for utility metering, built-in event and data stamping for instantaneous variables

WM50, I/O optional modules

- RS232/RS485
- Ethernet (Modbus TCP)
- 6-channel digital inputs, up to 4-relay/6-static outputs + OR/AND alarm logic management
- Direct An + Temperature + Process signal measurements

TCD12, sub metering

- Primary: 12*65 A
- Hole size: 8.5 mm
- Centre-to-centre distance: 17.5 mm
- RJ cable length: 30 – 500 cm
- 12-channel split-core current sensing unit
- Basic accuracy (V/A): $\pm 0.5\%$ RDG, class 2 (kWh) according to IEC/EN62053-21 (meter + TCD unit)
- Up to 96 channels: kWh, W, var, VA, PF, A, THD A
- Data available via communication module on board of WM50

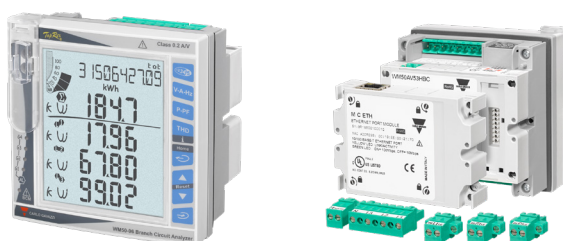

From main metering to submetering

Why a high-density metering solution?

In an industrial or commercial installation, in the same facility, the purpose of metering is not only load monitoring but also to establish energy cost centres for cost allocation, and when the machines/loads to be monitored are numerous, a standard metering solution is not the best answer. The point is not metering by itself, but more the need to shorten the payback time for this investment. How can you do it? By using a specific solution which has been designed, based on the application conditions mentioned above, to reduce the whole installation and commissioning time. It is the combination of ET272 meters (suitable to be used in both existing or new installations) with VMU-C (which automates meter addressing and in general reduces the whole commissioning process by 94%).

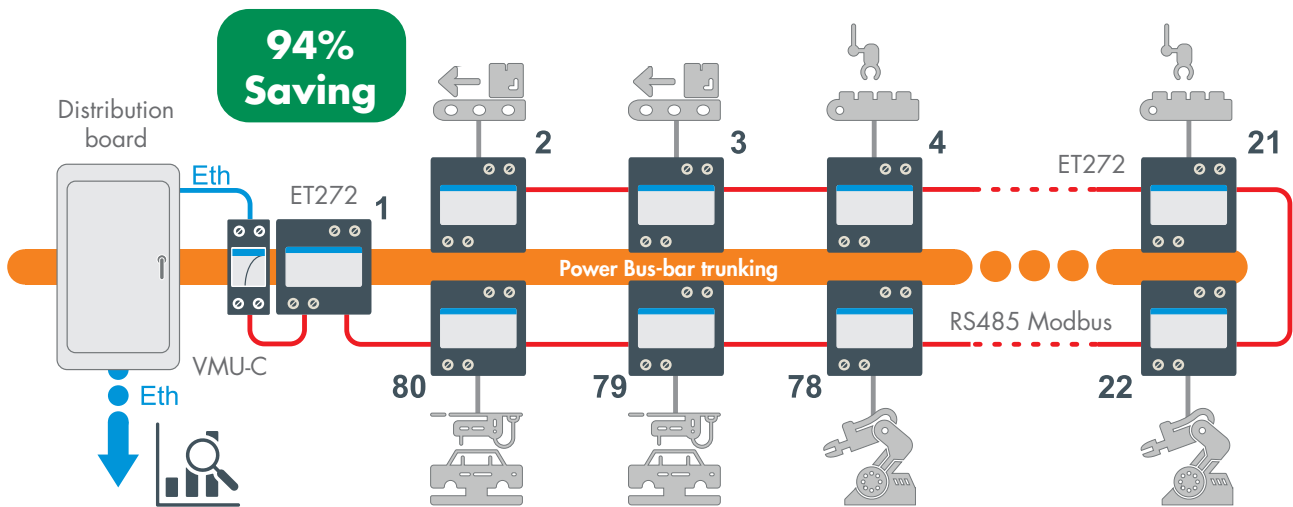

ET272, main and sub metering solution for tap-off boxes

- Patented meter, 4-DIN modules for DIN-rail mounting
- Up to 415 V L-L ac and TCD-based current measuring inputs
- Current measurement by two basic TCD units with quick RJ11 plugs (see TCD xM series)
- Quick configuration by automatic recognition of TCD units
- Self addressing in a Modbus system (in combination with VMU-C)
- 2*3-phase energy analysers with sum function in the same unit
- Measurements: V, A, Hz, PF, W, VA, var, bi-directional kWh
- Basic accuracy (kW): $\pm 2.0\%$ RDG (meter + TCD xM unit). kWh: class 1 (IEC/EN 62053-21)
- Data format: 3-DGT (instantaneous variables)/7-DGT (totalizers)
- RS485 Modbus RTU. 2 pulse outputs (loads 1 and 2)
- Universal power supply (230 V ac)

VMU-C gateway and web-server solution

- VMU-C EM and ET272 are mandatory parts of the bus-duct solution
- 2-DIN module housing. 12 – 28 V dc power supply
- Micro PC with embedded Web Server, WEB services and data logger functions
- Ethernet Modbus TCP master/slave function
- One RS485-Modbus port for the management of up to 80 ET272
- Data display (charts and tables). Real time or scheduled data export to Excel, CSV and HTML formats
- 4GB internal memory, Back-up memory on micro SDHC and USB
- Energy analysis of each load. Costs analysis
- Virtual meter with sum function
- Alarm management (e-mail or SMS by means of SH2-DSP)

TCD 0M-1M-2M-3M-MM, sensing solutions

- Triple split-core sensing unit for panel and DIN-rail mounting

Model	Primary (A)	Hole size (mm)
TCD 0M and TCD 1M	60 and 100	9.6 and 15.5
TCD 2M and TCD 3M	200 and 400	15.5 and 20.5
TCD MM	Up to 10000(*)	-

(*) using CTV current sensing units.



Up to 10kA

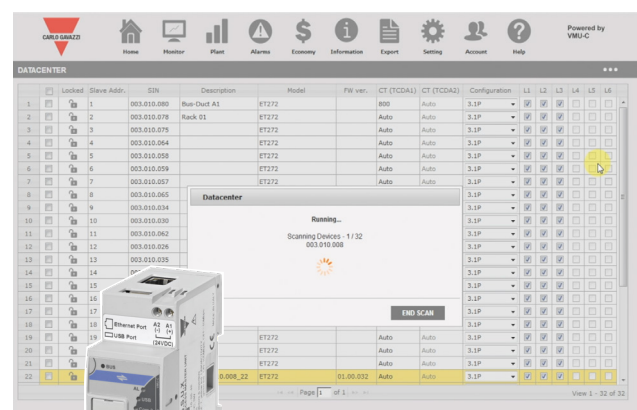

Monitoring

Load diagnostics

Critical loads ON/OFF status

Turning a motor ON doesn't automatically mean that it is running.

There may be failures around and the control system (a PLC or a Building Management System - BMS) must be informed that the action is not being delivered. The usual point is "how valuable is to know this early?", to trigger the actions to deploy as countermeasures. To deliver an answer to this question, Carlo Gavazzi has designed a critical loads ON/OFF status detection solution range, split in different models to meet the different installation needs. In a low-voltage switchgear, this range, with its compact size, saves space, with its through wiring simplifies installation and settings so as to reduce the total cost of ownership. Energy efficiency is not simply monitoring consumption, in fact low consumption doesn't mean the installation works properly because maybe motors are stopped for any reason, hence this can impact the efficiency of the whole plant.

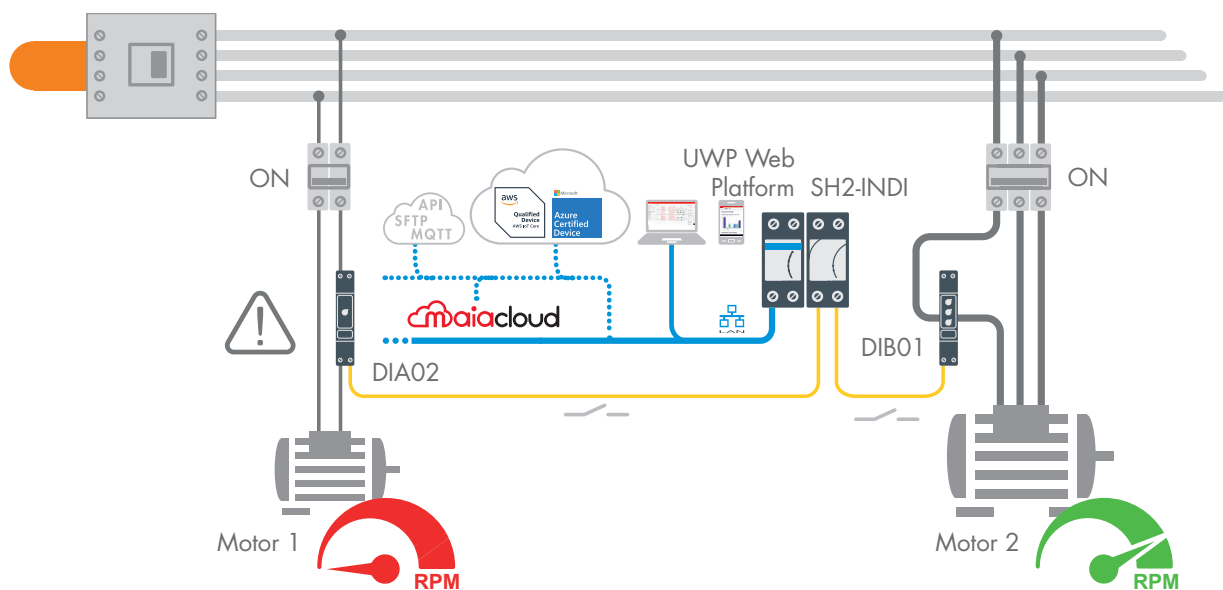

EIS-H

- Combined solid-state NPN/PNP 24 V dc or 230 V ac output
- Up to 60 A input current
- Built-in current transformer with 12 mm diameter hole
- Fixed setpoint: 200 mA (24 V) or 400 mA (230 V)
- 22.5 mm DIN-rail housing
- Self powered



DIA 53

- Combined NPN/PNP 24 V dc output
- Up to 100 A ac input current
- Built-in current transformer with 12 mm diameter hole
- Adjustable setpoint
- 17.5 mm DIN-rail housing
- Self powered



DIA 02

- Potential free change-over relay output
- 20 mA minimum load current to monitor very small loads
- 22.5 mm DIN-rail housing
- 24–48 V ac/dc or 115-230 V ac power supply



DIB 01 100 A

- Potential free change-over relay output
- Up to 100 A ac input current
- Built-in current transformer with 12 mm diameter hole
- 22.5 mm DIN-rail housing
- 24-240 V ac power supply



Load diagnostics in different applications

Some examples of applications where the benefits are widely larger than the costs.

Water circulation pumps in heating or cooling systems

These pumps are usually small, so the current to be detected may be below 1A. If used for hot water, when they fail the temperature of the building decreases quickly and some of the pipes run the risk to freeze. If with chilled water, the temperature of the building grows quickly and the quality of the ambient drops. In both cases, the building may need to be evacuated as non-compliant to be used as a working environment. Knowing immediately that there is a fault, that is as soon as the pump stops working, rather than when the air temperature change is perceived, gives time to the service team to fix the issue even before it's time to evacuate the building, avoiding the corresponding loss.

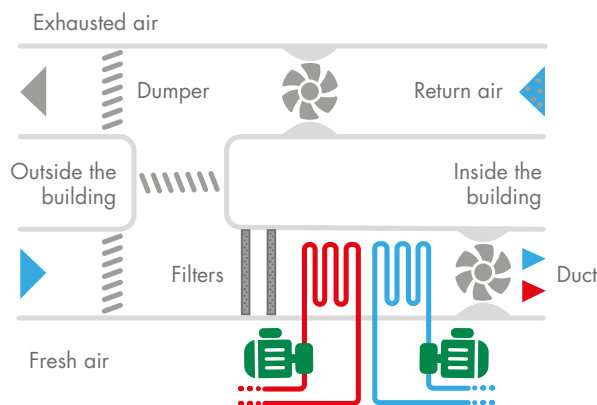

Chiller water circulation in Air Handling Units

Chilled water is provided using a pump. If it fails, the easiest and quickest way to detect the failure is to check if the pump is running. With this information the service team can be alerted to fix the issue before the quality of the air in the building isn't acceptable.

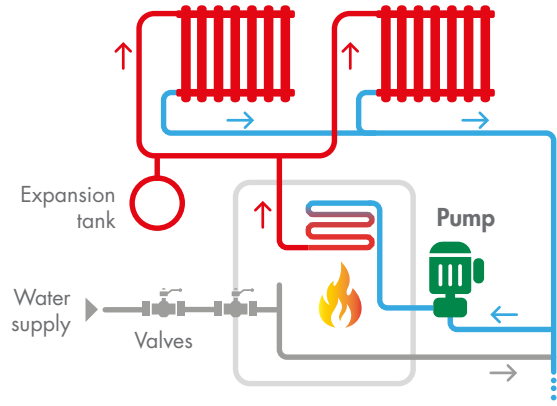

Fans in UPS battery rooms

The batteries in UPS rooms may release hydrogen and oxygen through their valves. If the gas concentration arises above the ignition point, the ambient becomes explosive. That's why battery rooms are equipped with a small extractor fan to ensure air exchange in the room. Failure of the fan means potential danger, and has to be addressed immediately, so knowing if it is working is crucial.

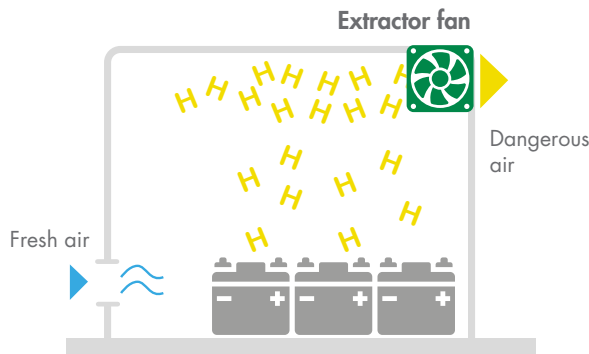

Active control

The map - multiple and different needs

■ Not only utilities and users but also buildings and occupants

The key objective of an energy efficiency plan is:

- minimizing consumptions (TOE, tons oil equivalent);
- minimizing costs;
- minimizing environmental impact (tons of CO₂);
- as a mandatory condition, ensuring the same productivity level!

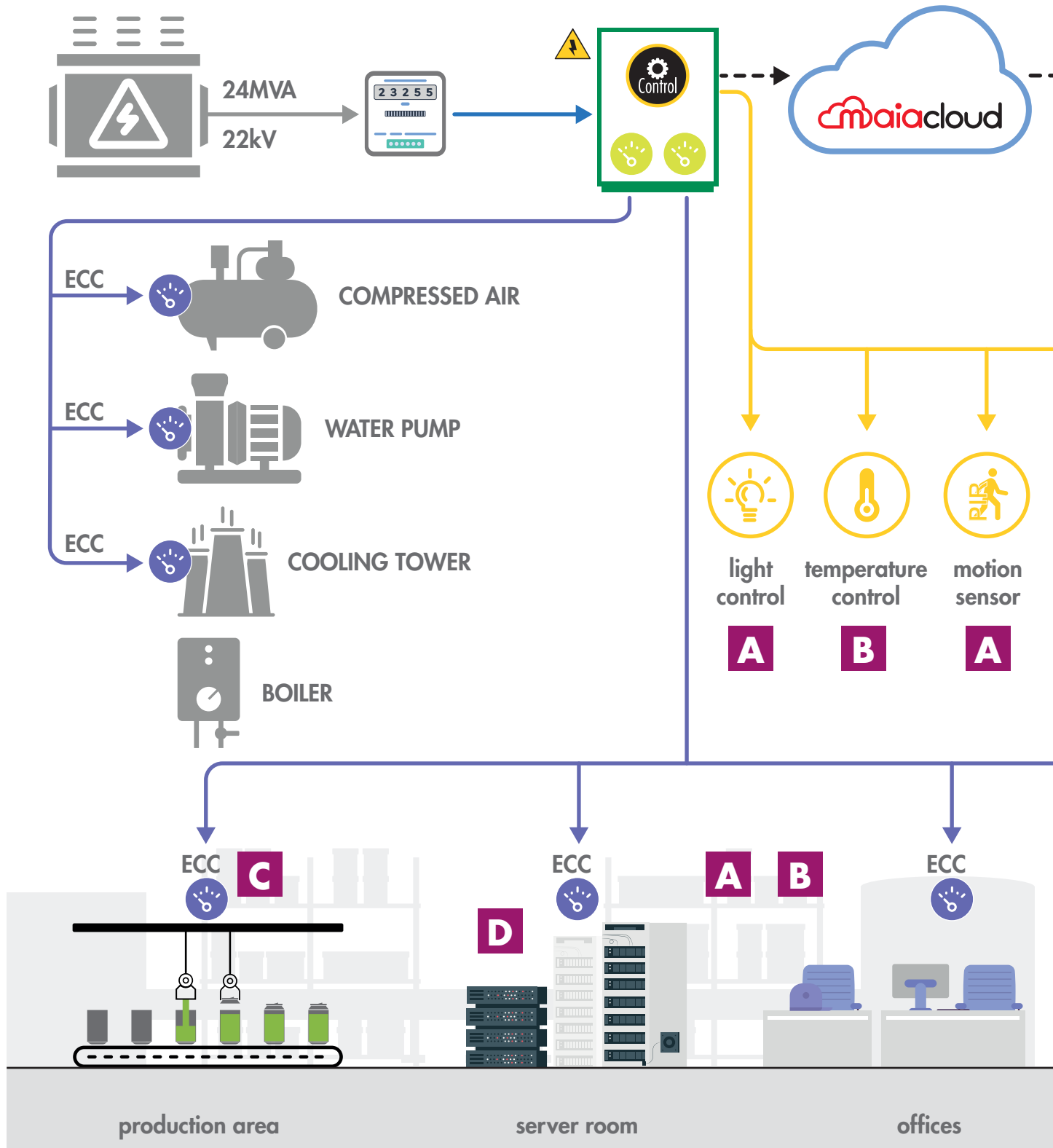



Carlo Gavazzi is part of the BACnet Manufacturers Association listed as an official vendor.

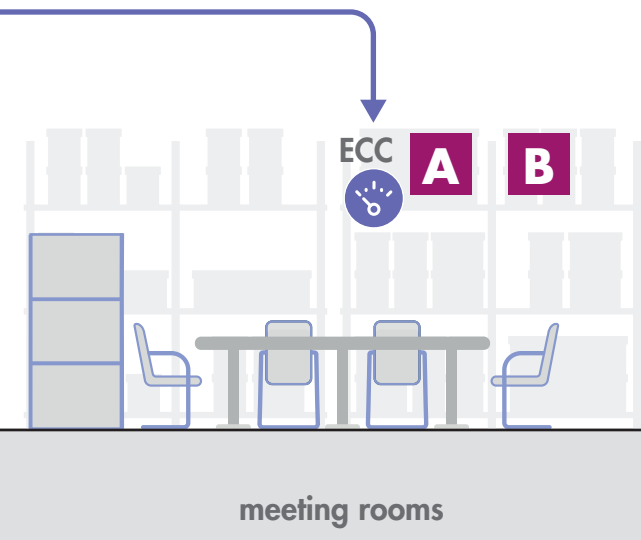
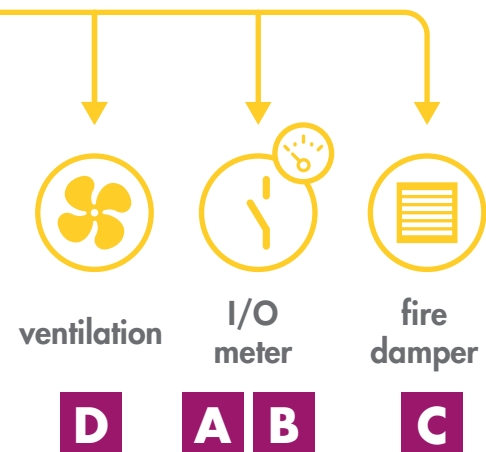

■ The energy performance of the building

Building Automation and Control Systems (BACS) can have a significant impact on the energy consumption of any kind of building and their occupants.

The EN 15232:2012 Standard: Energy Performance of Buildings in conjunction with the "Energy Performance of Buildings Directive" (EPBD) in Europe, as well as other standards (LEED, Energy star) in other regions, are the guides to achieve the planned energy efficiency goals.

Those standards are aimed to provide:

- a list of control, automation, and technical management functions that affect the energy performance of buildings;
- a method for defining the minimum requirements for the control, automation, and technical building management functions implemented in different types of buildings;
- detailed procedures for quantifying the impact these functions have on the energy performance of a building;
- a simplified method to obtain an initial estimate of the impact these functions have on the energy performance of buildings.

Carlo Gavazzi, with its global offer of products, solutions and competences, evolves its product portfolio from energy efficiency monitoring solutions to active control through building automation.

Being able, in an existing installation, to keep the same wiring or to simplify it, upgrading the technology, adding new functions, is beneficial to achieve the planned energy savings.

 **Active controls**

 **Measurements**

ECC: Energy Cost Center

The topics

	Page
 Automation platform	44-45 46-47
 Energy and people efficiency	50-51 52-53
 Wired and wireless environmental probes and I/Os with multi function meter	54-55
 Fire damper control solution	56
 Critical loads ON/OFF status	32-33

All products in this document are both CE and UKCA compliant

Active control

The essential platform based on UWP 3.0 SE

to meet metering and building efficiency for small to medium installations.

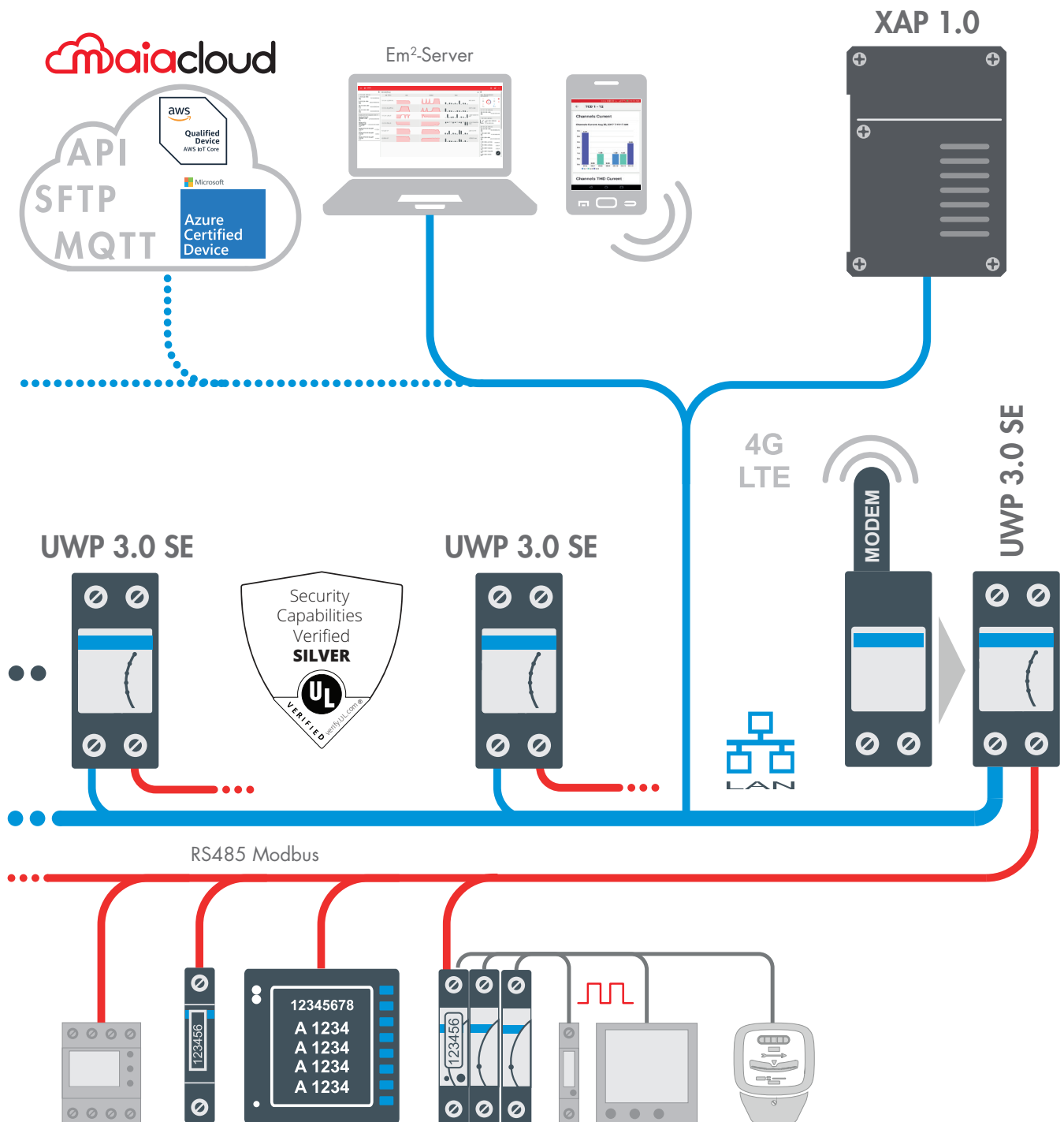

■ The architecture completion

Fast commissioning, cost reduction and error-proof configuration, make the UWP 3.0 SE a powerful tool for achieving energy efficiency goals. The platform progresses from pure monitoring to active control. Whilst automatic gathering of all the meter data is crucial, it is insufficient to achieve the greatest possible energy reduction. Therefore, monitoring and active control are two key actions that work together to maximise energy efficiency and energy cost savings.

■ The active control

The active control provided by UWP 3.0 SE is the platform's capability to act at a first-level, directly and automatically on the load while the second-level integrates with other management systems.

For example, an industrial plant may consist of several buildings like a production facility with services, offices, and a warehouse, all with different needs in terms of load control and integration. Each of these buildings has a particular load management and integration requirement. Energy-intensive loads including huge machinery, electric heaters, chillers, and air compressors are present in the production plant. They must all be monitored and optimised. Additionally, it is necessary to divide up the cost of energy by ECC energy cost centre (see our extensive meter offer). meter offer).

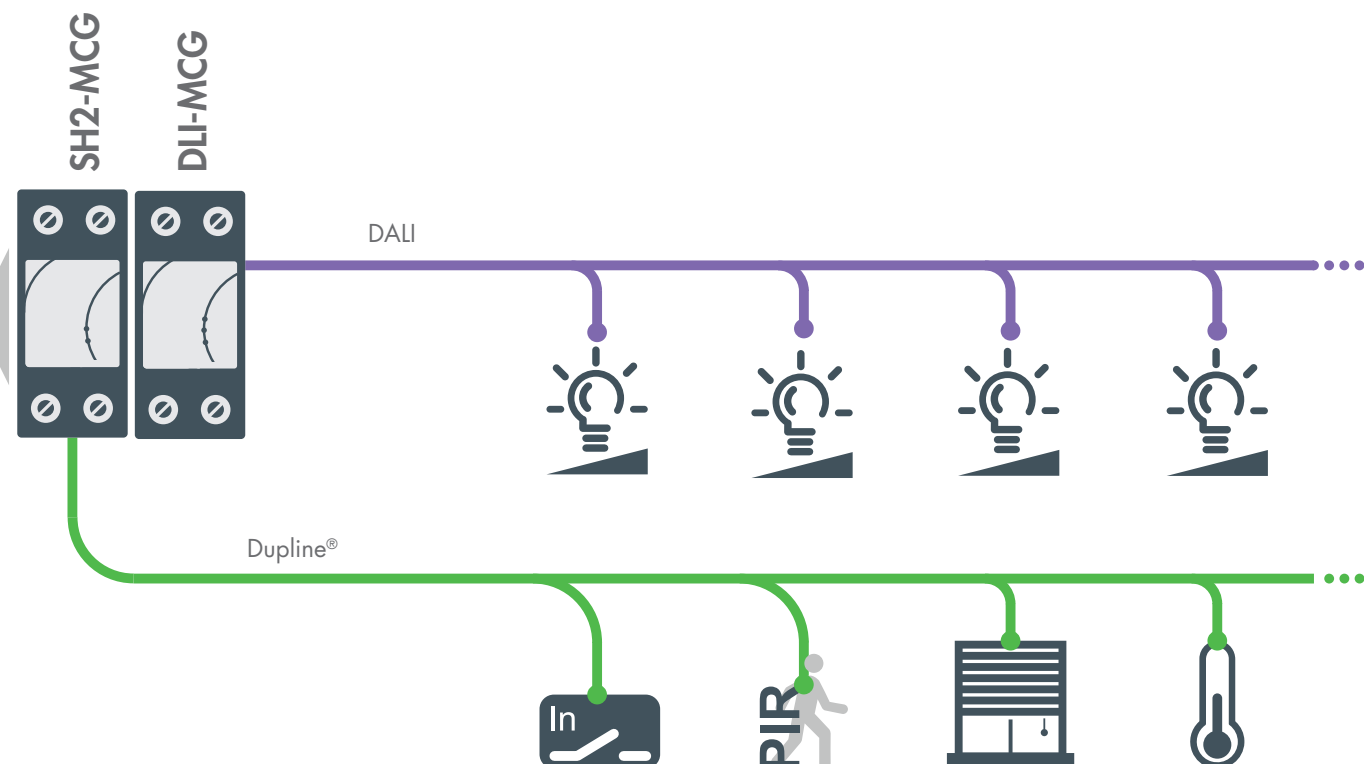

Active control

The scalable platform based on UWP 4.0 SE

to provide a full integration into a BEMS for large installations.

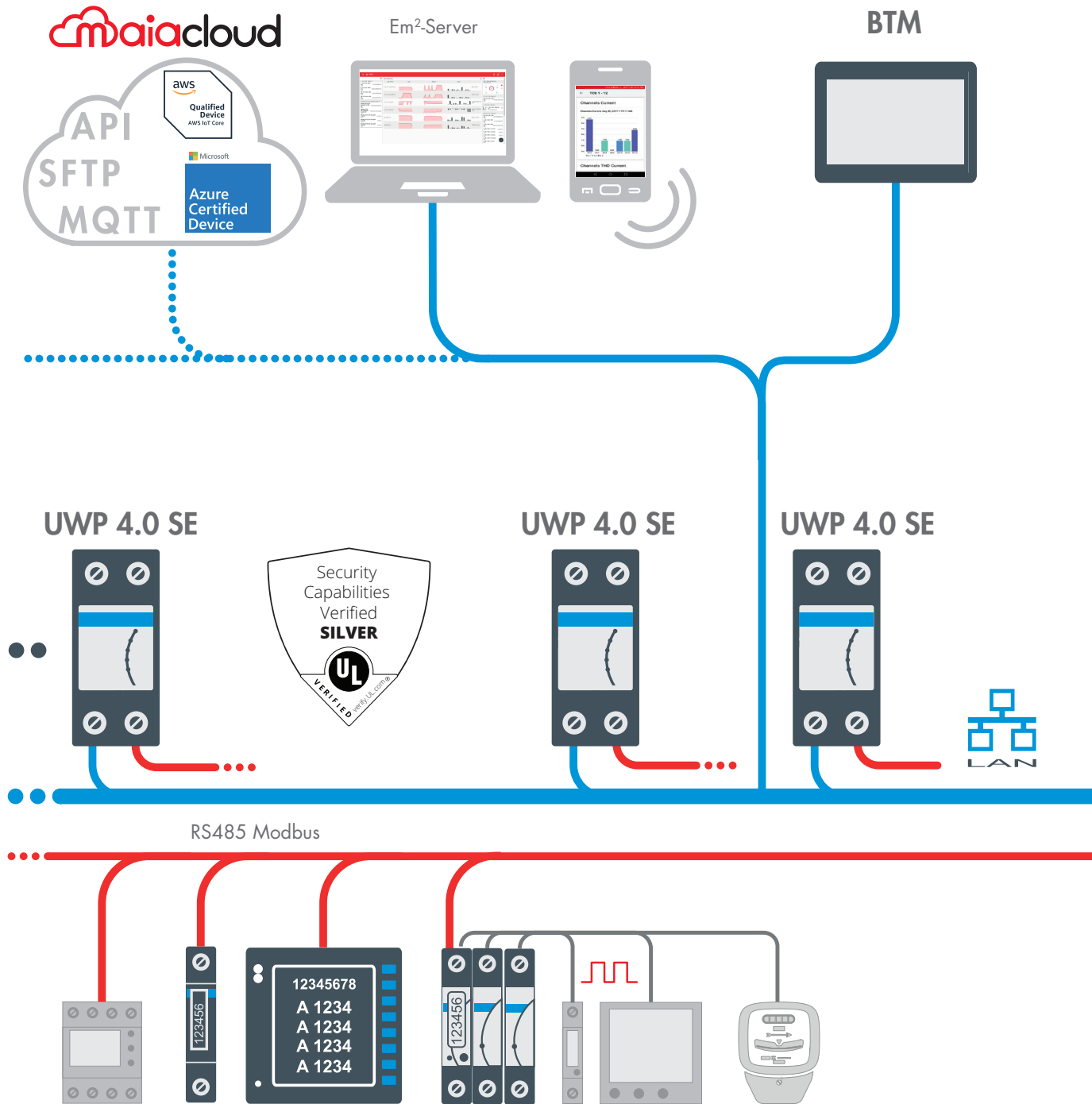

■ Beyond UWP 3.0 SE

The UWP 3.0 SE is the best solution for small to medium size installations due to the ideal trade-off between cost and performance, UWP 4.0 SE offers a more flexible option with a number of benefits for the more demanding Energy and Building Efficiency applications. A strong ecosystem that combines both hardware and software to effectively meet the needs of end users, the energy market, and applications, which may include redesigning of the electrical grid.

■ Digitalisation and scaling-up capability

Digitalisation is the new buzzword, and IIoT evolution is the key to participating in a market that will increasingly be centred on data management to meet the demands of the future. As part of a strategy to combine monitoring with practical energy-saving measures in the field, UWP 4.0 SE offers an energy-efficiency focus with DALI-2 lighting control. UWP 4.0 SE Ecosystem provides a full monitoring package for integrators and energy managers who require an easy-to-deploy solution without the need to purchase pricey software and hardware integration from different suppliers.

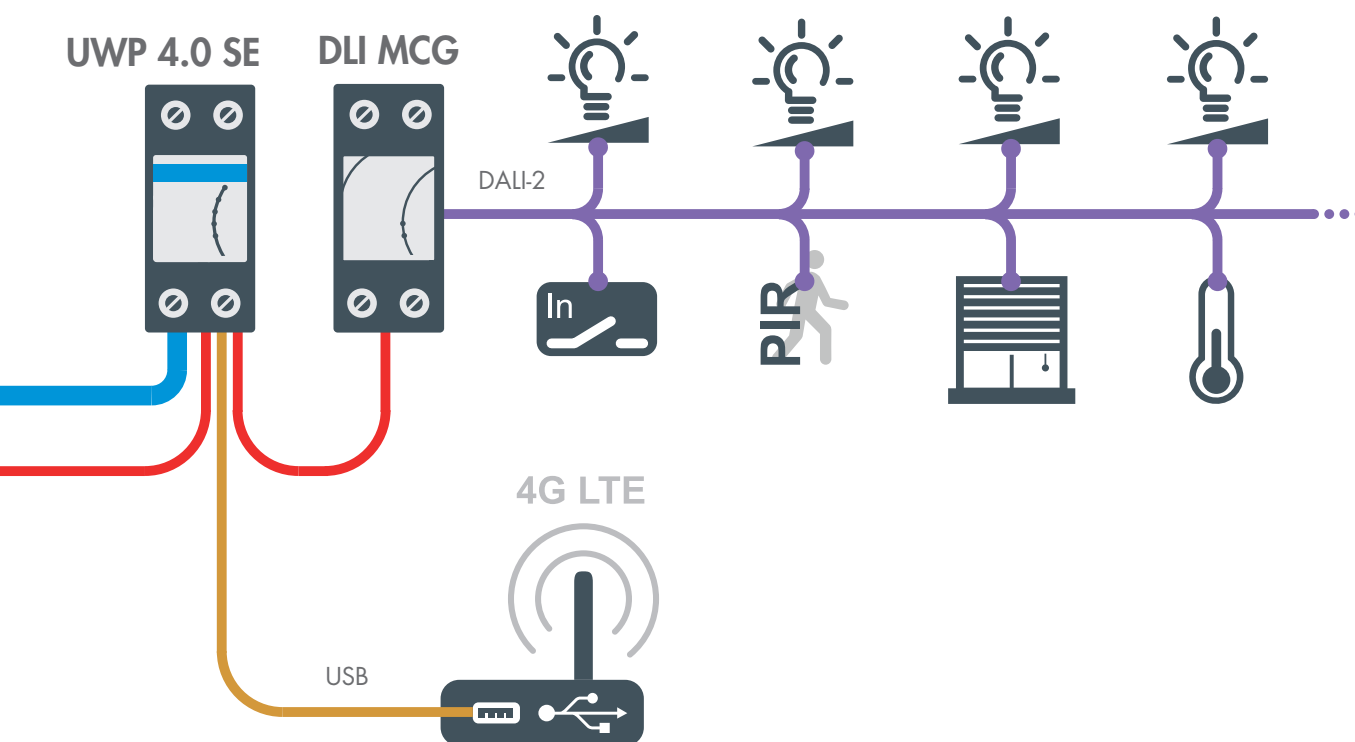

Active control

The architecture technologies

One solution from Field devices up to Management

Efficiency is not only electric or on the transformation process, it is also human.

Energy savings and human efficiency

In the offices there is the need to maximize energy efficiency in relation to the external environmental conditions and people occupancy, while providing the highest levels of comfort, safety and quality. Lighting is one of the major areas to focus on, so to reduce electricity costs. A proper controller module based on DALI-2 bus provides a wide range of control strategies to achieve both energy savings and comfort level. Efficiency is important not only for energy resources, but also for human resources. A modern company knows that people engagement, mood, and commitment can be easily enhanced taking care of the work space in terms of CO₂ level (ventilation), temperature (heating and cooling), and illumination (DALI-2).

Control and integration

Last but not least, in the warehouse the main energy users are lighting, heating, and ventilation. A proper management of those loads and the communication by means of BACnet, will integrate the UWP 4.0 SE platform into a BMS so to complete the offer to achieve the energy efficiency goals.

Beyond communication networks, the BACnet communication integration

Learn more

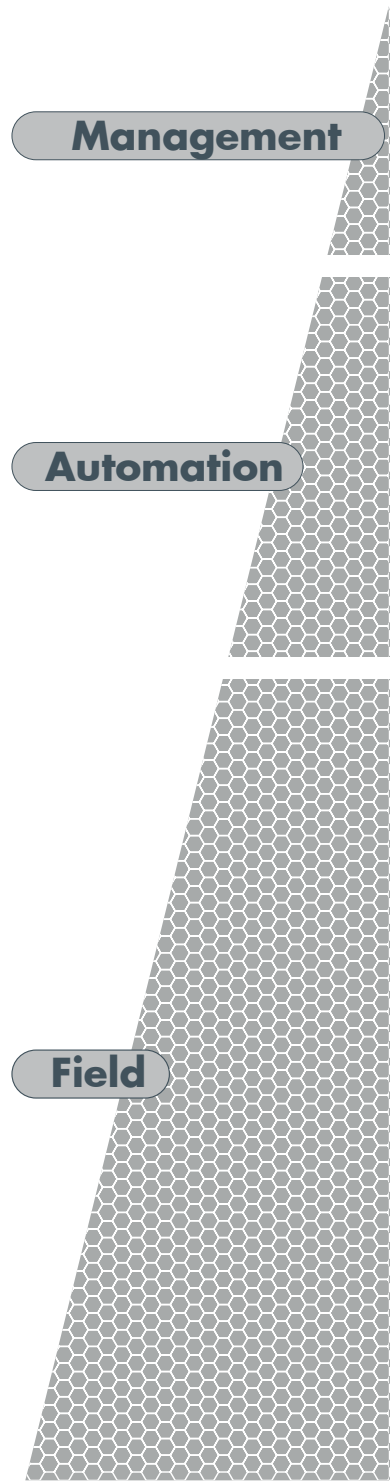

BACnet powered digitalisation and more

BACnet means a specific data communication architecture and protocol designed to ...

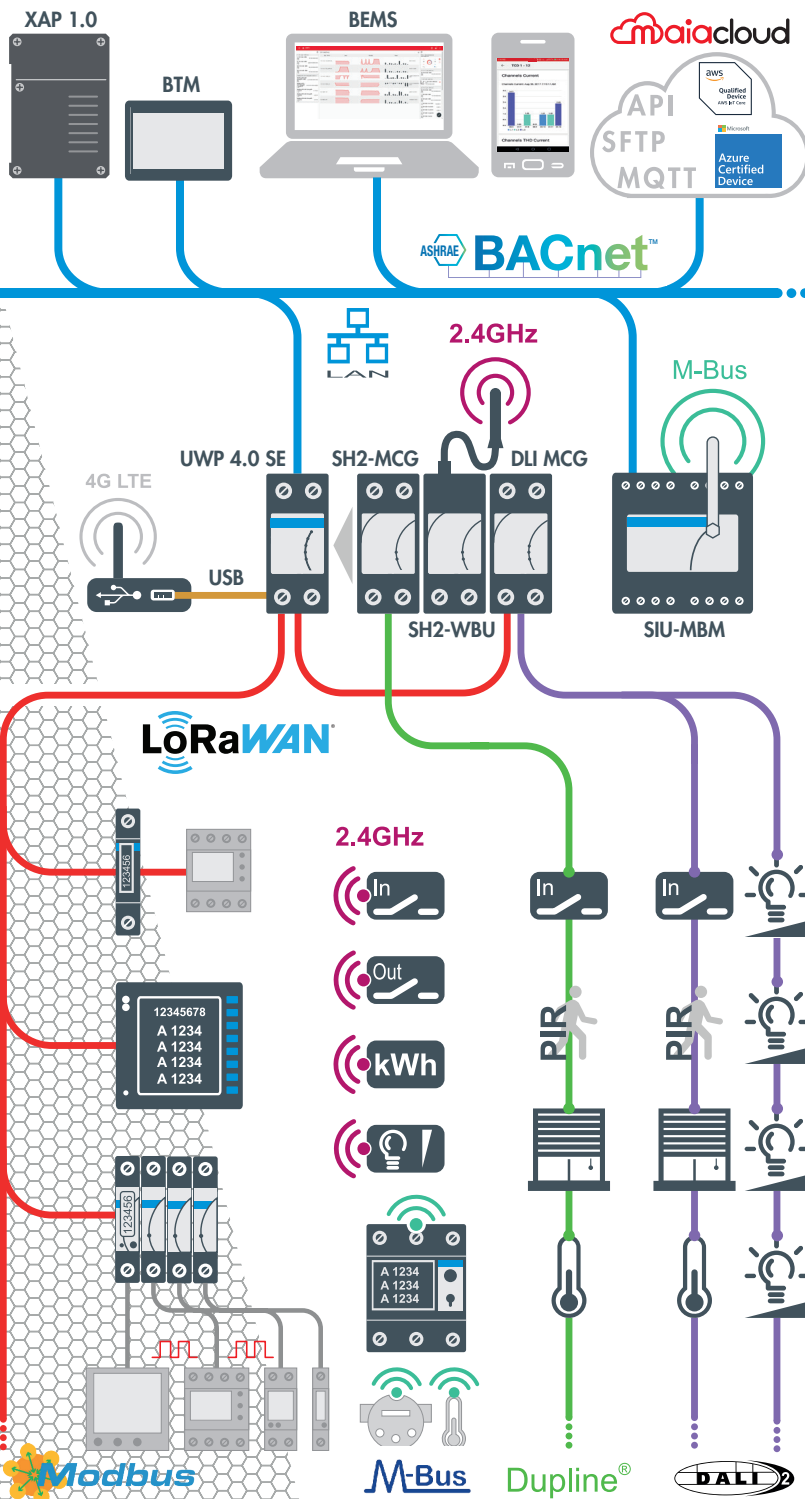

... provide mechanisms for computerized building automation devices to exchange information, regardless of the particular building service they perform.

■ This means a data exchange and management of heating, ventilation, and air-conditioning control. But also lighting control, access control, and fire detection systems and their associated equipment to achieve the energy efficiency and saving goals. While communication networks are used extensively in Building Automation systems at the automation and management levels, they are less used at the device level, especially within HVAC control systems. In most cases, each data point needs its own wire(s) back to the DDC (Direct Digital Control), which complicates the installation in case of widely distributed data points, meaning, cost issues and device level complexity.

■ While on one hand UWP 4.0 SE significantly simplifies the field level of HVAC and lighting wiring without increasing material costs, on the other hand it reduces both commissioning and BACnet integration time.

■ UWP 4.0 SE is a multi protocol unit which means, in a BACnet world, the central unit of the system. It interfaces to XAP 1.0 the DDC's (Direct Digital Controls) and the BMS (Building Management System) through BACnet/IP, managing up to 7 Dupline® bus generators. and up to 20 DALI-2 master modules
Carlo Gavazzi is part of the BACnet Manufacturers Association (BMA), is listed as an official vendor, and provides BTL certified products.

Active control

The smart field bus wiring

The Dupline® bus

Dupline® is the smart fieldbus to exchange information between smart field sensors and the UWP 3.0 SE core unit and platform.

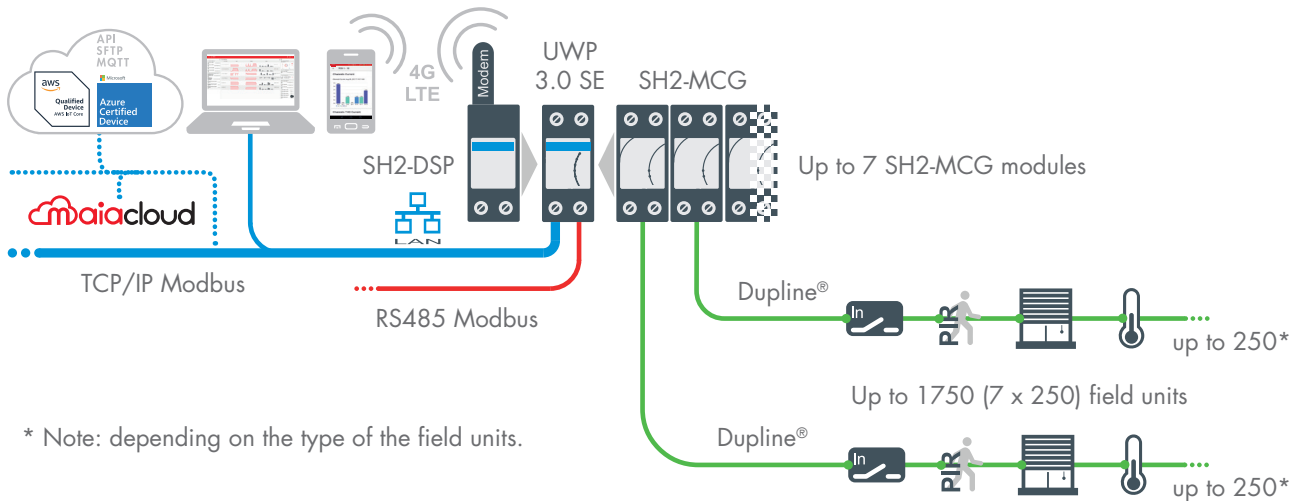

Why the Dupline® proprietary smart bus?

Because among all the platform compatible standard field buses, Dupline® is the best solution in its application context, since it brings numerous benefits, such as:

- eliminating expensive shielded cable, saving money just because it uses a twisted pair (2 wires);
- being extremely noise immune, can run next to power cables;
- carrying the power supply to power the connected sensors;
- simplifying the field level wiring (based on free topology) without increasing the material costs (e.g. using existing cables);
- running the bus signal up to 2 km (1.24 mi) without any repeater;
- being robust with a proven technology with over 150,000 installations worldwide including not only energy efficiency solutions but also mining, oil drilling, railroads and many others;
- being modular and scalable, the system can be progressively extended with new modules (up to 7) according to the application needs.

SH2-MCG

- Connection to UWP 3.0 SE via internal bus or terminals via the high speed bus
- Up to 7 SH2-MCGs can be connected on the same network, considering the sum of SH2-MCGs and SH2-WBUs
- 2-DIN modules housing
- 24 V dc power supply

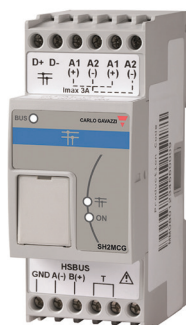

The noise and crosstalk immunity of Dupline®

- 1) Inductive coupling effect in parallel wires.
- 2) Minimizing the inductive coupling effect in Dupline® twisted Cables.

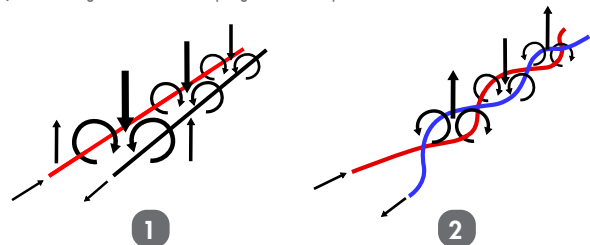

The free topology of the Dupline® network

Ease of installation and wiring.

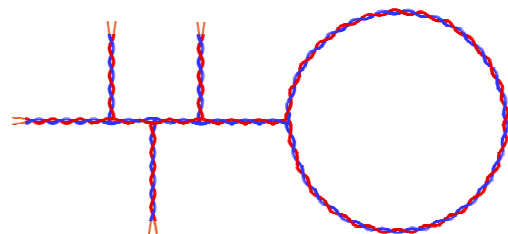

Only 2 wires to perform a reliable communication

Many wires vs. two wires, this is the Dupline® smart field bus!



Specialised sensors for a changing world

Being able, in an existing installation, to keep the same wiring or to simplify it, upgrading the technology, adding new functions, is beneficial to achieve the planned energy efficiency savings.

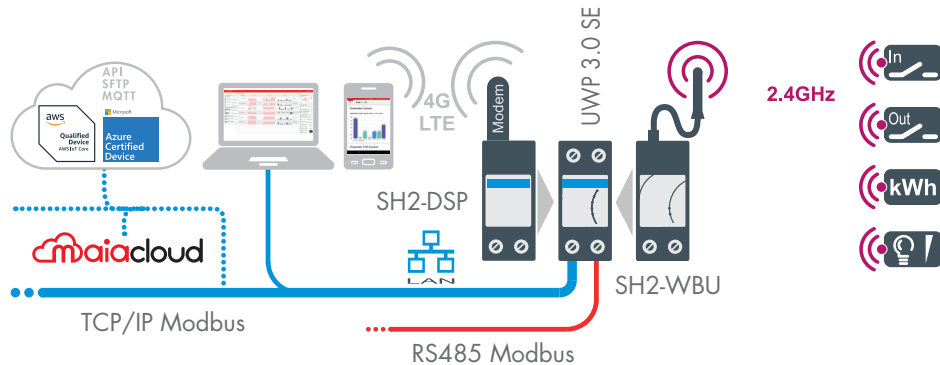

This means, within the UWP 3.0 SE platform, the availability of Dupline® smart field components suitable to:

- measure environmental parameters, such as temperature, humidity and CO₂;
- measure luminous flux per unit area (LUX);
- measure standard signals, such as volts and milliamps from various transmitters;
- measure the energy consumption of single-phase loads;
- detect movement and presence within a room;
- sense status signals, such as light and load switches and alarms;
- activate outputs by means of relays;
- generate 10 V dc analogue signal outputs;
- display and locally adjust temperatures.

Moreover, also different combined and streamlined sensing and actuating components, specifically designed to meet space constraints and cost savings.

A complete set of units capable to measure ambient parameters and to manage input and output signals aimed to provide all the necessary information to the platform through the UWP 3.0 SE core unit. This becomes the ecosystem which with proper algorithm boosts the energy savings.

Even if the smart wired Dupline® brings many installation and working benefits, it may happen that a totally wired architecture is technically not possible. In that case, the solution is to add the IEEE802.15.4 2.4 GHz wireless expansion module "SH2-WBU" to build up a wireless network, where other Carlo Gavazzi field smart units can be added to expand the platform capabilities. This means:

- 4 programmable push buttons to turn ON/OFF lights;
- 4 digital inputs with embedded counter function;
- a light dimmer with embedded single-phase energy analyzer;
- a relay output with embedded single-phase energy analyzer.

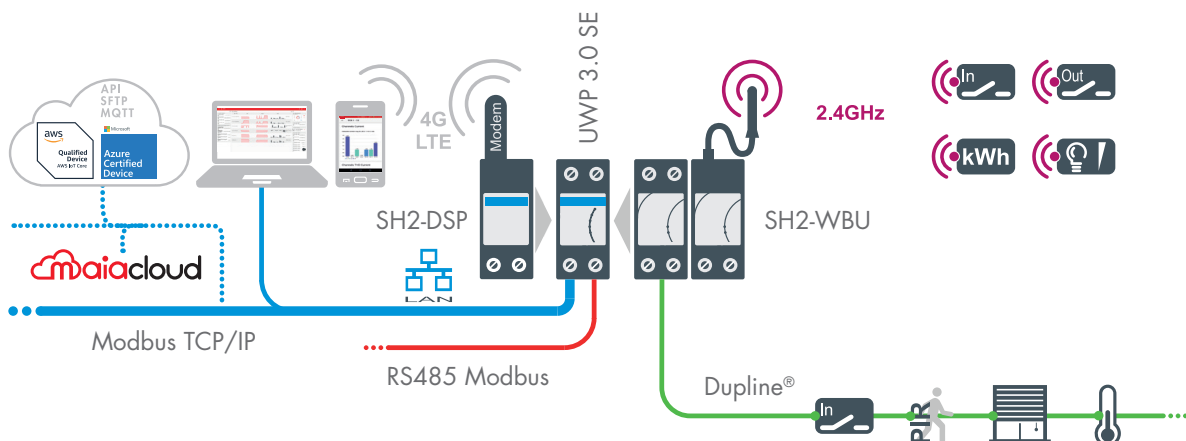

Active control

XAP 1.0 the eXtended Automation Platform

■ Flexibility, scalability and integration capability!

In a medium to big industrial site or building, the need is to collect a massive amount of data generated by field devices like meters and sensors. These data have to be brought where they need to be processed and managed to implement an effective Energy Efficiency plan, thus saving natural resources and consequently also preserving the environment. In this respect, it is important to have a flexible system suitable to the different local needs. Being a production facility something that changes very often due to process reviews, scalability is a must. Moreover, to be able to meet an Energy Efficiency plan, there is the need to interact with users, to exchange data with new or already existing systems using different communication protocols, but also with Cloud-based systems. In a system, this means being able to manage an efficient and effective integration.

■ Why is it fundamental to manage data in an efficient and effective way?

Nowadays, data management is fundamental to achieve the saving goals, but this is very often a hassle for the system integrator. There are two orders of problems:

- the first one is related to the way data is exchanged, therefore the protocols used, and as a consequence the potential lack of know-how;
- the second one is the data interaction and the logic to be implemented to achieve the energy saving goals.

Both problems are costs which will be paid by the end users, but will also limit the competitiveness of the companies providing the solution and services. How to solve those problems? From the point of view of the system integrator, by making the architecture lean by using as few devices as possible in the data exchange, and from the point of view of the Energy service Companies, by easily implementing proper control logics.

■ One step further!

When architecture complexity increases, to be able to meet additional integration needs and to automate the management system, the UWP Web Platform is only a part of the solution. To complete the architecture there is the need to add a further powerful device which goes beyond both UWP 3.0 SE and UWP 4.0 SE features. It is XAP 1.0, the ultimate compact controller and gateway with embedded IIoT (Industrial Internet of Things) for seamless connection of multiple and various devices and sub-systems. Using the standard IEC61131 CODESYS, XAP 1.0, it supports network stacks and local I/O expandability. It provides easy programming, while the configurable web interface makes it an outstanding web HMI, with easily programmable graphic pages, functions, and protocols. The two Ethernet ports offer network segregation for WAN/LAN. XAP 1.0 is simple to connect to other devices as it offers multiple embedded standards, such as CODESYS, OPC UA, KNX IP, and BACnet, as well as data distribution via MQTT. The Linux-based operating system is designed to be interference resistant, while HTTPS provides secure web server access. By providing internet and web-server capability, XAP 1.0 together with both UWP 3.0 SE and UWP 4.0 SE, are the supervision and control solution to ensure optimisation of lighting, HVAC and in general building automation functions which can dramatically decrease energy usage and in turn the energy bill!



FTP

XAP 1.0



UWP_{3.0 SE}

UWP_{4.0 SE}



Automation functions

Edge units

Field devices

Active control

XAP 1.0 the eXtended Automation Platform

Flexibility, scalability and integration capability!

XAP 1.0, a compact, IIoT-ready controller and gateway for seamless connection of multiple and diverse devices and sub-systems.

XAP 1.0 is aimed to deliver a complete solution for both industrial and building automation, from BMS down to field devices being XAP 1.0 the management level, UWP 4.0 SE the edge automation level, and the Dupline® and Modbus devices the field level. XAP 1.0 integrates the Codesys V3 development environment based on a solid Soft-PLC engine for programming controller applications according to the international industrial standard IEC61131-3. In order to be able to interact with industrial processes, XAP 1.0 integrates OPC UA client and server capabilities thus connecting databases, analytic tools, ERP, and other systems with real-world data from low-end devices. As modern processes involve cloud technology and services, the Node-RED connector has been embedded to connect hardware devices and online services (MQTT, FTP, SMTP) as part of the IoT world. XAP 1.0 among many available tools and functionalities is powered by a configurable web interface which makes it an outstanding web HMI, which can be easily programmed with graphic pages, functions and protocols, thus contributing significantly to system optimisation, ensuring total and integrated control.

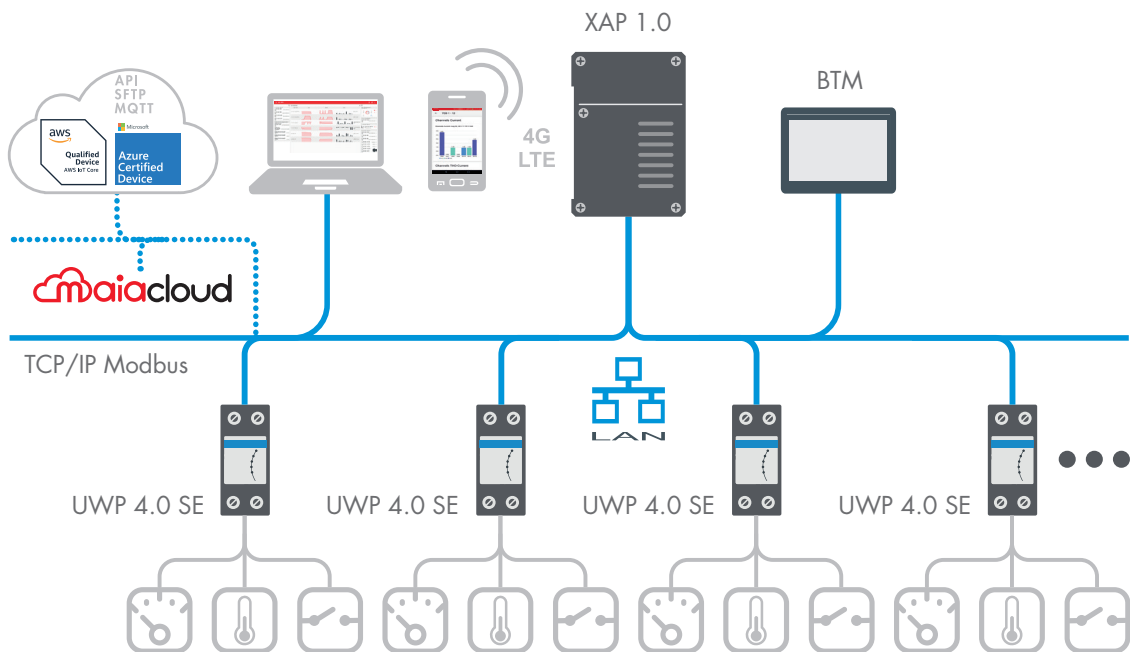

XAP 1.0

- Controller and gateway, web HMI, PLC for building automation functions
- Data communication: OPC UA
- Cloud connectivity: Node-RED (Optional)
- Operating system: Linux
- Secure web server access: HTTPS
- Protocols: Modbus RTU/TCP-IP master and slave, BACnet client
- Other protocols: OPC-UA, MQTT
- Compatible with CODESYS V3: it supports network stacks and local I/O expandability
- 2 Ethernet ports for network segregation from WAN/LAN
- Customisable web interface, with different access types according to the type of user
- Connectible to UWP 4.0 SE via BACnet or Modbus/TCP
- 24 V dc power supply

Learn more



A combination of tools in one solution

In a medium to large industrial site or building, the need is to collect a massive amount of data generated by field devices like meters and sensors to implement an Energy Efficiency plan.

In such applications, architecture complexity is a rising problem, together with additional integration needs and a high level of data exchange. In addition, to be able to achieve the saving goals, also data interaction and logic complexity have to be managed properly. XAP 1.0 is the solution to those problems, being one core device with easy protocols management, able to manage a high level of data exchange and interactions with proper logic tools. In an ordinary architecture, the configuration of the whole system may impact the TCO (Total Cost of Ownership), that's why XAP 1.0, as an advanced system, uses an advanced user interface so to be more effective, and SCADA functions or web pages can be created for any type of application via the BTM Studio Software.

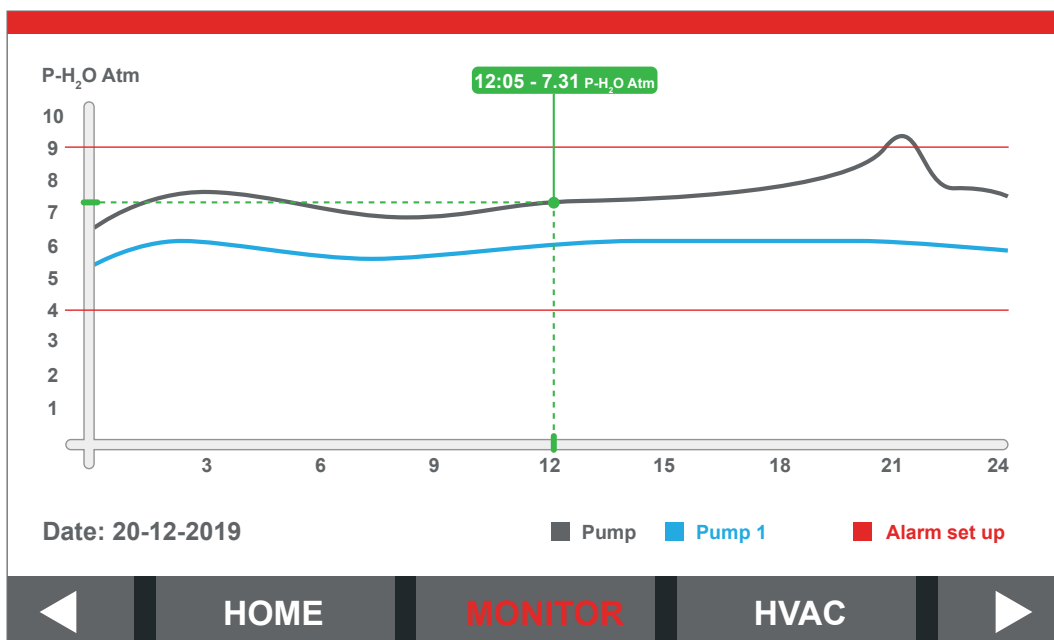
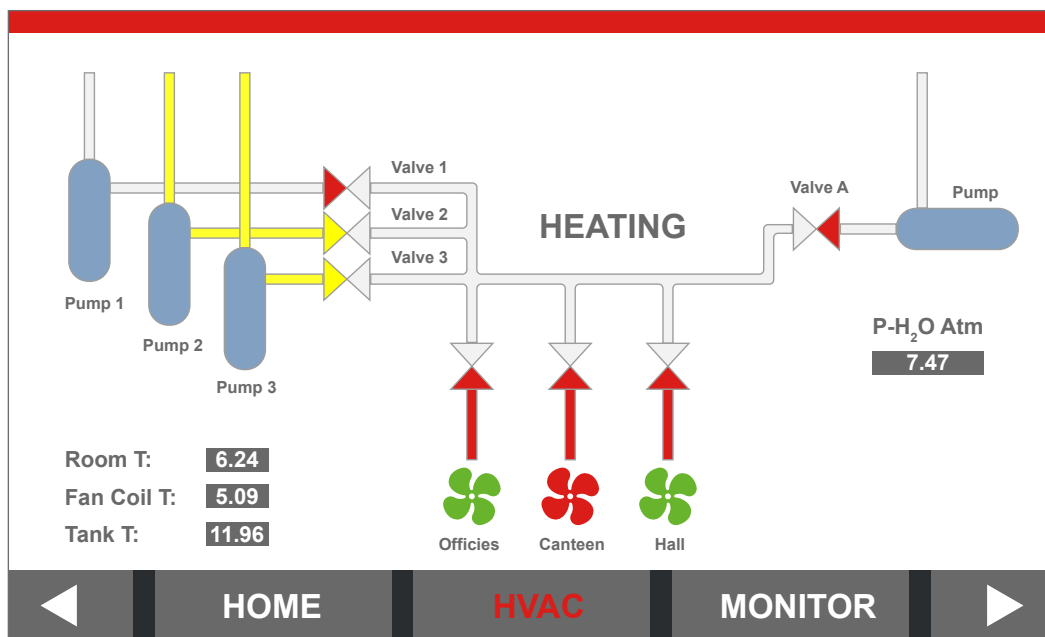

Active control

Beyond communication networks

From tunable white to building efficiency

Both UWP Web Platforms can be enhanced, if needed, adding to the BACnet/IP communication bus the DALI for UWP 3.0 SE and the DALI-2 for UWP 4.0 SE worldwide standard buses.

Helping the application to maximize energy efficiency in relation to the external environmental conditions and occupancy of the building, while providing the highest levels of comfort, safety and quality. Lighting in buildings, is one of the major areas to focus on in order to reduce electricity costs, so the ability to control and monitor is a key feature that can easily be achieved by means of both flexibility and scalability of the UWP Web Platform. The provided main control strategies are:

- daylight harvesting, which provides automatic dimming to compensate for the amount of natural light;
- automatic sunrise and sunset calculation;
- real-time clock and schedulers to switch ON/OFF, dim or change scenario;
- light level control according to people presence and timers;
- zone control.

Lighting strategies are connected to building occupants

These advanced functions are not enough to meet the more demanding lighting needs, which nowadays are not limited to the energy savings only. The Carlo Gavazzi platform implements, through specific DALI master units also the DALI (Digital Addressable Lighting Interface) bus, also its evolution DALI-2. This means a unique and wide range of control strategies which can be adapted at any time according to the changing needs of the building occupants. The remarkable success of both DALI and DALI-2 is also due to its very easy installation (just two non-polarized wires with free topology), its low commissioning costs (no certified wires or fees are required) and last but not least, its scalability, robustness and flexibility.

Nowadays people are the most important resource a Company must take care of: people engagement, mood, and commitment can easily be enhanced taking care of the work space in terms of CO₂ level, temperature and illumination, which means people performance and efficiency. This means, in different words, that people's biological clock is regulated by light and darkness as shown in the graph below.

The temperature of white light influences people's performances

The graph shows how our hormones change during the day according to the colour temperature: cortisol is our waking hormone, whilst melatonin controls our sleeping rhythm. A warmer temperature is more relaxing, while a cooler temperature creates a motivating environment. As a consequence, the white colour of lamps influences people's performance and efficiency. Thanks to an ever-improving LED technology, all the mainstream LED lighting companies are moving to offer products which can change the white of the light from warm (2500K) to cold (6000K) to follow the behaviour of natural white. This feature is called "Tunable white" or Kelvin colour temperature change or CCT (Correlated Colour Temperature) and is the capability of changing the temperature (K) of the colour of the light.

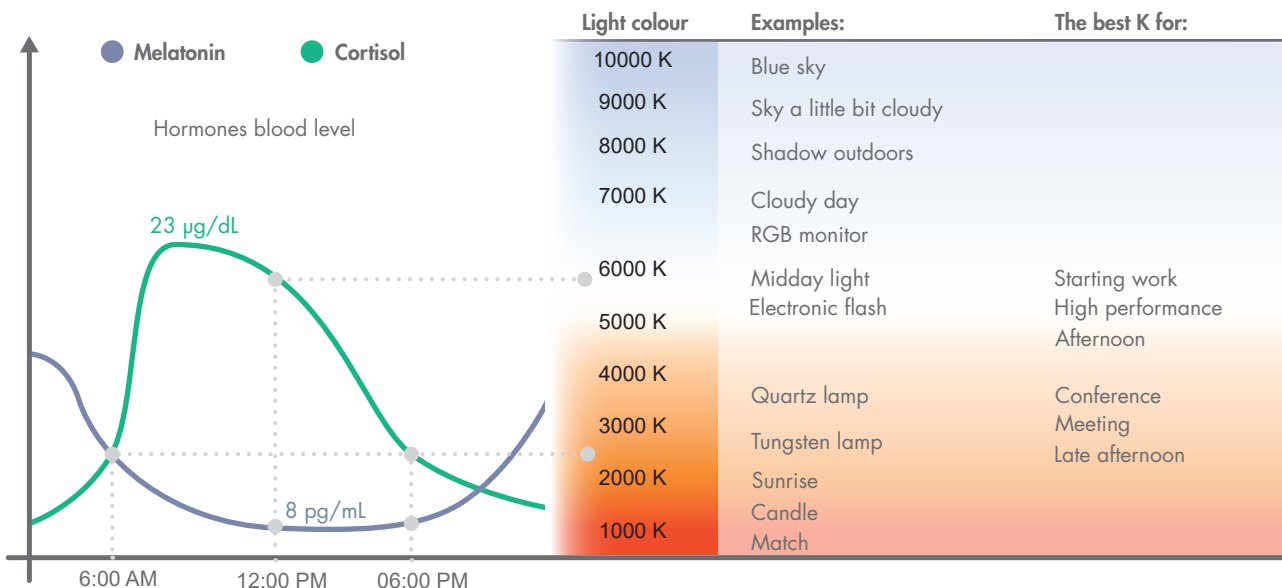

Lighting exposure has an impact on the mood

In offices where people have little access to the beneficial properties of daylight, static lighting conditions might disrupt the biological rhythm.

Thanks to the SB2-DALI specific module when combined with UWP 3.0 SE or DLI-MCG specific module when combined with UWP 4.0 SE and the embedded "Tunable White" features, independently from the external environmental conditions, it can provide the perfect atmosphere for each activity during a working day. Cooler temperatures to support concentration and focus or to compensate for an afternoon dip in energy levels, warmer temperatures during activities which require creativity and cooperation.

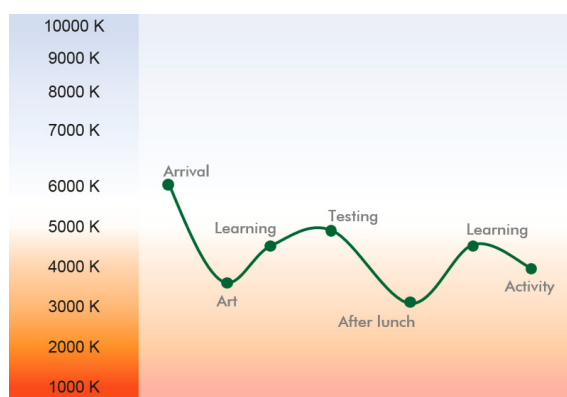

Light temperature vs. daily activity in a school.

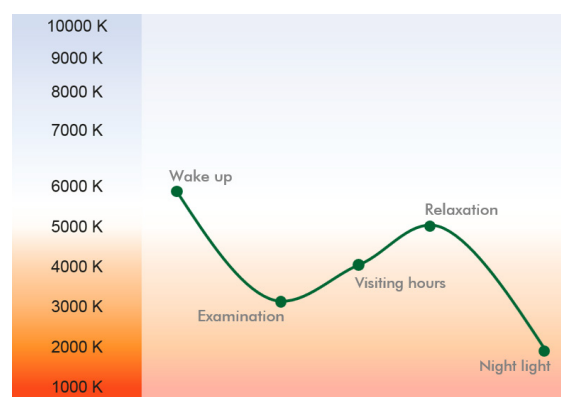

Light temperature vs. daily activity in a hospital.

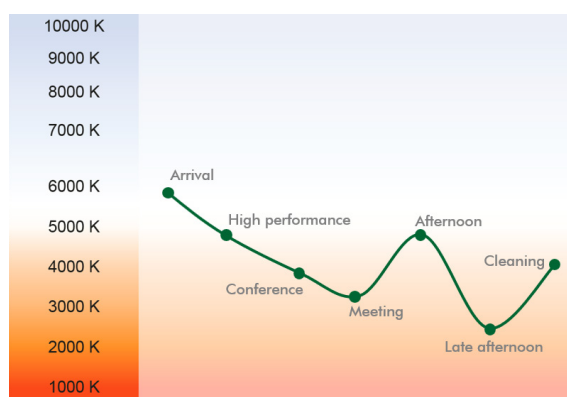

Light temperature vs. daily activity in an office.

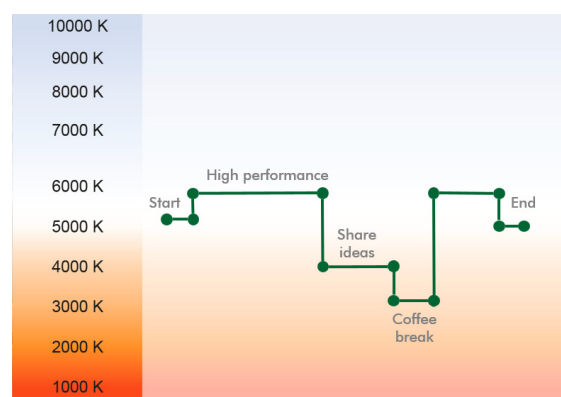

Light temperature steps vs. daily activity in an office.

Lighting system and human's health

Additionally, studies have shown that light exposure has an impact on the mood and reduces symptoms of depression in individuals. Exposure to light has also been directly linked with health and can affect how we recover and heal. Rooms with large, sun-facing windows reduce recovery time for patients suffering from severe depression and those recuperating after heart attacks, compared to similarly afflicted patients in rooms with windows facing buildings or other obstructions. Reduced exposure to daylight has been linked to the onset of depression and impairment of cognitive function in individuals. Studies show strong links between better views, brighter light and better performance in office environments.

The lighting environments where humans spend their time impact their visual, circadian and mental health. Currently, lighting conditions in most spaces are designed to meet the visual needs of individuals but do not take into account circadian and mental health. This presents an opportunity for projects to provide lighting conditions required by humans for optimal health and well-being.

WELL aims to provide a lighting environment that reduces circadian phase disruption, improves sleep quality and positively impacts mood and productivity, see also HSE (Health-Safety-Environment) standards.



Active control

Precise control for a green building

The evolution of the lighting

If most energy waste is due to inefficient room temperature management, misuse of lighting is largely underestimated.

It doesn't matter if the building is for industrial, commercial or public use, the common problem is how to make lighting part of the energy efficiency plan, but also, how to make people more efficient. As proper ON/OFF light switches are an obvious part of this offer, passive infrared (PIR) movement detectors with programmable sensitivity and embedded lighting measurement together with light dimmers are the offer completion to carry out an effective control by automatically switching off the lights when either people are not occupying the room or there is enough day light in the room.

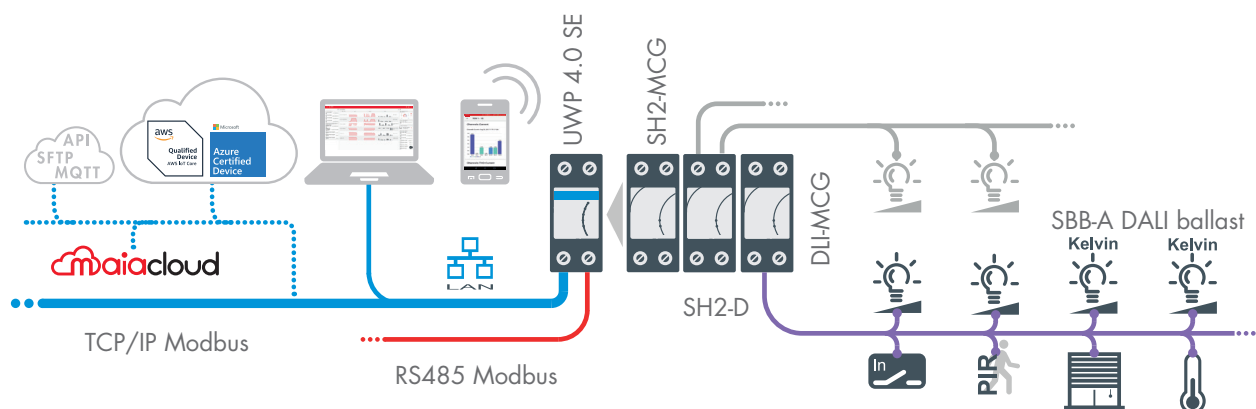

DLI-MCG

- DALI-2 Sub-Master with embedded power supply, capable to manage up to 64 DALI-2 control gears/ballasts
- A DALI-2 network can manage: input devices (switches, dimmers, presence sensors and so on); output devices (switch gears/ballasts, drivers and so on)
- Up to 20 (*) DLI-MCG024 units can be connected to an UWP 4.0 SE controller
- (*): Up to 4 DLI-MCG024 units can be connected to UWP 4.0 SE if each of them is connected to 64 DALI-2 control gears and 64 DALI-2 input devices
- Lighting control functions are performed by UWP 4.0 SE, including switching, dimming, scenarios, calendars, constant light, white balance. UWP 4.0 SE allows to easily integrate the DALI-2 network into BEMS systems via BACnet or Modbus/TCP or to manage the whole lighting control system by means of its powerful web interface
- 2-DIN module housing
- 230 V ac power supply

SBB-A

- 2 constant current output channels, total output power up to 50 W
- Output current level selectable from 250 mA - 1500 mA
- Built-in DALI interface, DALI DT6 and DT8 ballast. DALI approval
- Colour temperature adjustment: device Type 8, colour Type Tc

DLI-P360

- Passive infrared detector (PIR)
- Detects movement and presence
- Indoor and outdoor applications
- DALI-2 certified solution
- Lighting measuring range: 0 – 80 K lux
- Walk test: LED indication
- Programmable white and blue LED and detection area
- Operating angle: 360°
- Detection range (diameter): from 14 m (45 ft) to 24 m (78 ft) according to the model
- Mounting height: from 2 m (6.5 ft) to 8 m (26.2 ft)
- 4 individually programmable push buttons

SH2-D

- Universal dimmer switch for R, L, C loads up to 500 W and LEDs loads
- Two models available: with and without embedded energy analyzer
- Automatic load type detection: R, L, C
- LED-indications for power supply, bus and output status
- Push button for local ON/OFF switching
- 2-DIN module housing
- 115/230 V ac power supply

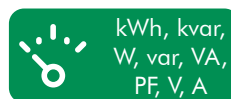

A software to configure quickly and easily your system

Programming is half of the cost of an installation, but thanks to the UWP IDE configuration software, this activity is extremely shortened.

The master unit UWP 4.0 SE is programmed by means of the configuration software UWP IDE, freely downloadable from the Carlo Gavazzi website. UWP IDE, has been developed to make commissioning fast, easy and error free. It guides the user step by step in the creation of the map of the installation and of the automation functions. Furthermore, it is an essential tool for the diagnostics of the installation: the bus and any connected device can be easily monitored. Remote and secure set-up is possible via MAIA Cloud.

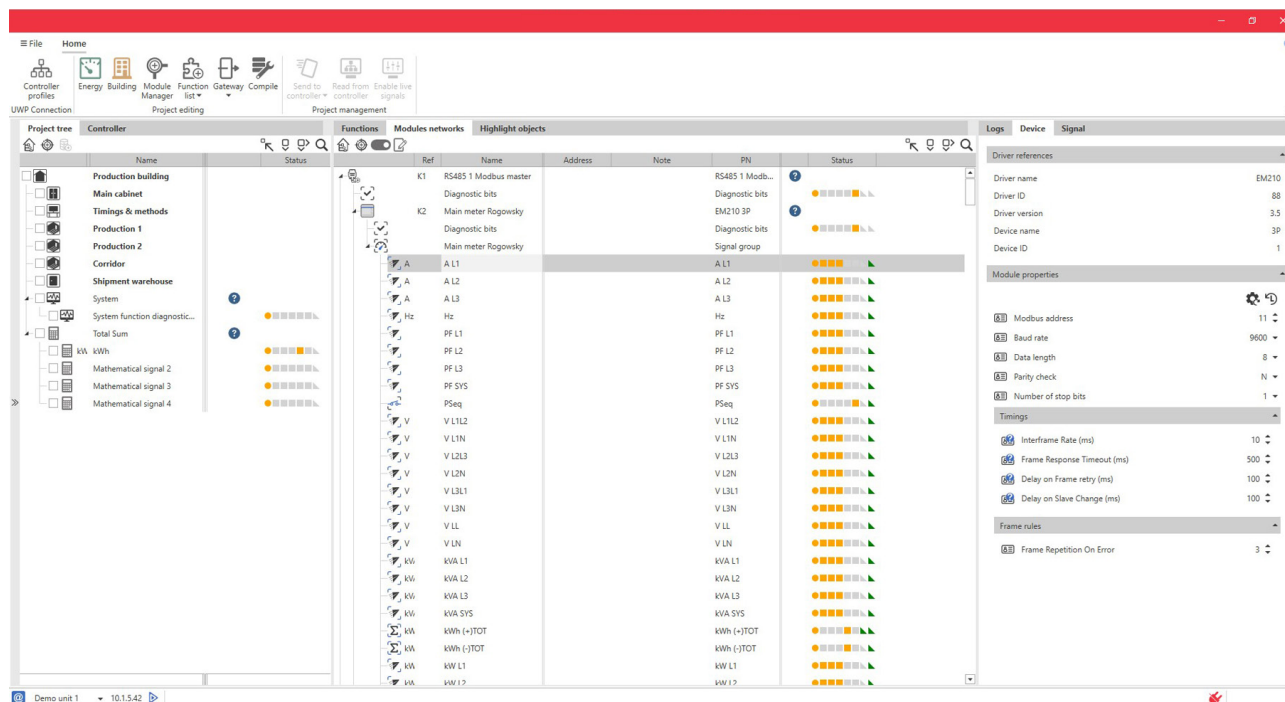

Fast commissioning

As soon as the software is connected to a master unit UWP. All the Carlo Gavazzi meters, sensors and actuators can be easily selected a set-up by means of the Module Manager within UWP IDE.

Report

Anything which is happening in the system is monitored in order to issue a warning if something goes wrong. All this information is logged in a file so that the installer can check it any time.

Diagnostics

Should any trouble occur, the system provides powerful diagnostic functions in order to make fault finding much easier. The bus is always monitored, providing information about short-circuits, bus voltage and bus load, noise level, and quality of the bus signals.

Clear view

When commissioning a project, it is very important to have a clear overview of the installation to place modules and quickly create logics. Afterwards, a well-structured location tree will help in reminding what has been done or troubleshoot. A commissioning report can be generated by the UWP IDE, helping installers to document the status of the project.

Save time

The icon and picture based wizard guides the installer/integrator in a straightforward and error free programming, since everything is very immediate and no memory efforts are required. The UWP IDE provides an integrated Web-Help and an automatic protocol-mapping documents generation based on the actual devices and functions in use.

Easy testing

Thanks to the live signals function, it is very easy and straightforward to test the logics. Everything can be done in front of the PC: enabling and disabling the functions, changing the parameters to reach the perfect settings, or trouble shooting. Besides, MAIA Cloud provides secure remote operation.

Active control

Not only lighting efficiency

Energy efficiency and people efficiency

DALI-2 technology makes a working ambient more energy efficient but also more people efficient.

The DALI-2 technology which Carlo Gavazzi has embedded into the DLI-MCG unit is a step beyond an energy efficiency program, since it provides, through the available LED-based lighting systems, functions like "Tunable white" and "lighting scenarios" to influence people's working performance.

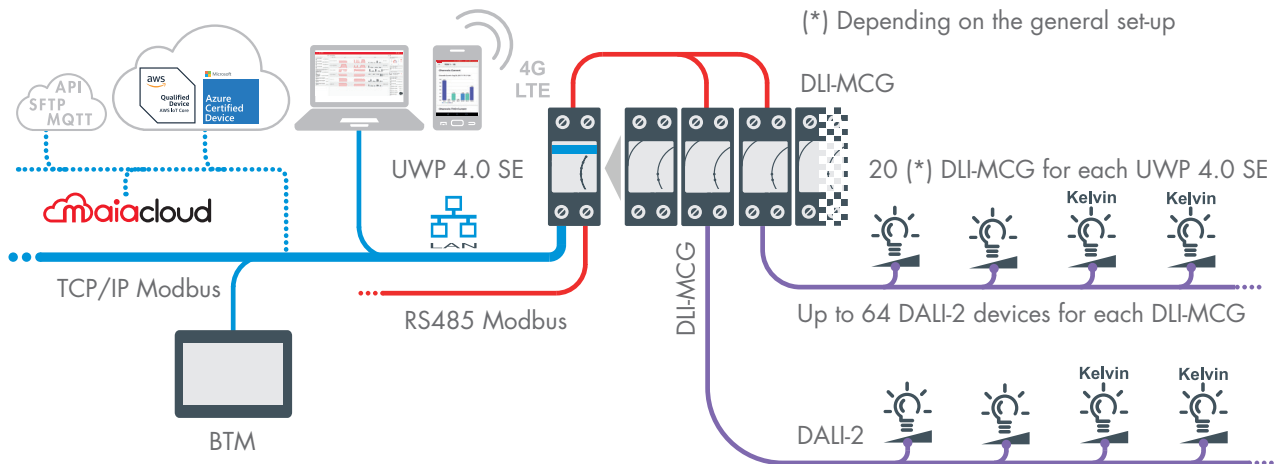

People efficiency can make a company more competitive

Understanding business energy costs, energy management, and people efficiency can make a company more competitive. This depends not only on energy efficiency and energy management, but also on the working environment for the workers. The latter can be addressed and improved by the control of CO₂ level, temperature and illumination which means people performance and efficiency. Being able to change the working environment according to specific needs is the key to the success of the solution. That's why Carlo Gavazzi provides a dedicated end-user app to turn a smartphone into a powerful remote controller. It also provides a family of HMI panels with 7", 10" and 15.6" display footprint including also BTM Studio suite which is a powerful integrated development environment to design and manage a wide range of applications so to meet all the energy saving strategies.

BTM-T7, BTM-T10

BTM-T7

- 7", 800 x 480 pixel
- Dimensions 187*147*34 mm

BTM-T10

- 10", 1024 x 600 pixel
- Dimensions 282*197*34 mm

BTM-T7 and BTM-T10

- TFT resistive touchscreen, 64 k colours
- 1 Ethernet port, 1 USB port, Multistandard serial port
- Linux operating system
- Fully programmable by IDE software
- IIoT data distribution via MQTT and OPC UA
- BACnet, Modbus communication protocols
- Data logging
- 24 V dc power supply

BTM-T15

- 15.6", 1366 x 768 pixel HD
- Dimensions 422*267*64 mm
- TFT capacitive multitouchscreen
- 16 M colours
- 3 Ethernet ports, 2 USB ports, SD card slot, multi-standard serial port
- Linux operating system
- Fully programmable by the IDE software
- IIoT data distribution via MQTT and OPC UA
- BACnet, Modbus, KNX communication protocols
- Data logging
- 24 V dc power supply

BTM Studio suite

This Windows suite is made by three licenses:

BTM-PC-IDE software

- large embedded widgets library to design and manage HMI projects
- Wide range of communication protocols to meet all different application requirements
- OPC UA server / client for Industry 4.0 applications to exchange data among HMI, PLC and devices
- MQTT service for IIoT messaging compatible with any MQTT broker
- Unified programming approach for native and web HMI applications with HTML5 and Javascript support
- Easy integration into the UWP 3.0 SE ecosystem through plug and play import of Modbus maps and EDE BACnet files

BTM-PC-RUNTIME: A powerful PC Runtime application turns any Microsoft® Windows® computer into a HMI panel

BTM-PC-CLIENT: is a viewer



Right at your fingertips

In today's world, apps are essential tools for our everyday life: so why don't you control your building via an Android or iOS device?

Any mobile device can be turned into a remote controller thanks to the integrated web app, available both for Android and iOS phones/tablets. The pages of the App can easily be customised with graphs to monitor the consumptions, the temperature of a room or the level of a light. Many widgets are available to switch and dim lights, to change temperatures, to set the curtains position and in general to remotely control any function of the system. The Web-App embedded into UWP 4.0 SE does not need a licence fee and can be operated remotely via MAIA Cloud.

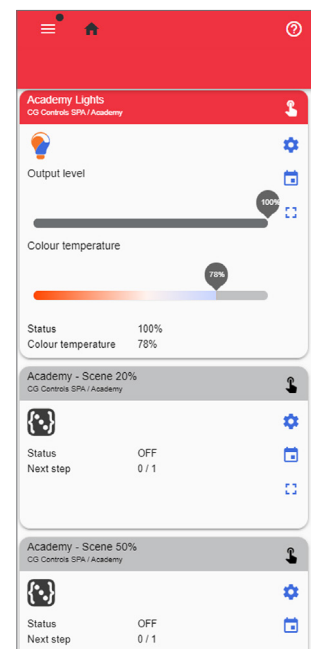
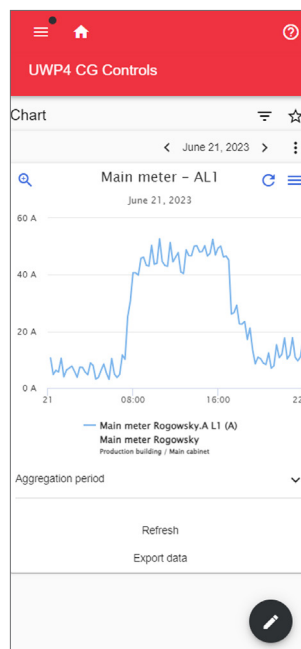
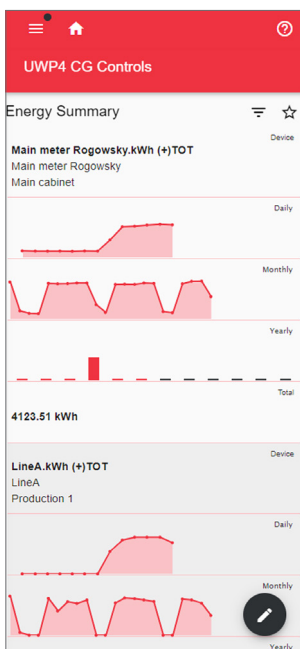
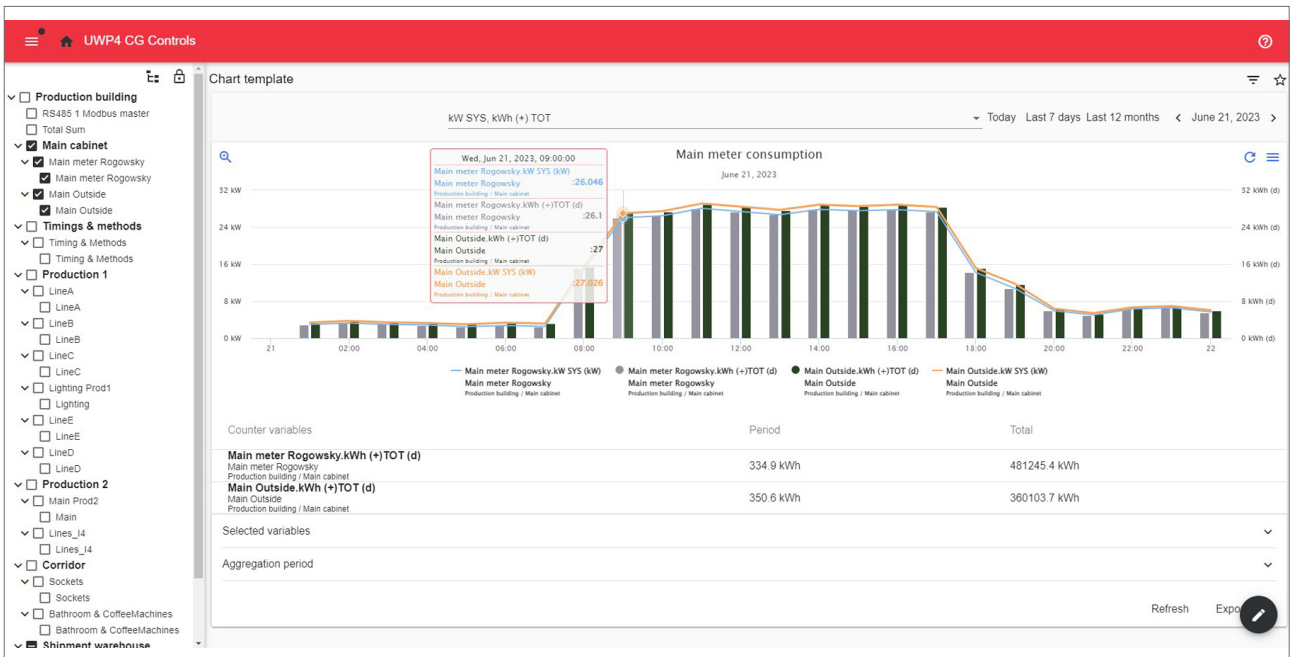

Active control

From environment to actions

From wired environmental probes to I/Os

Wired sensors are essential components of every metering and control system.

In Industrial, commercial, and public buildings, the combination of temperature, humidity, CO₂, and other non-electric and electric variables is essential to the management of the proper energy carriers. This means that air heating, cooling and ventilation, but also air quality information must be collected and managed to implement a proper energy efficiency plan. The UWP 3.0 SE platform, equipped with bus powered smart field devices, is the most effective answer, featuring specific field units, such as analogue inputs to measure signals from various temperature sensors, but also standard process signals (10V/20mA); single and combined wall mount sensor units with onboard display, digital inputs to detect alarms and ON/OFF switches, smart relay outputs to activate valves/actuators with signal feedback (by means of embedded energy analyzers) for real-time diagnostics, and last but not least, remote controllers with embedded display. To be able to meet the different installation needs, most of the devices have specific configurable functions.

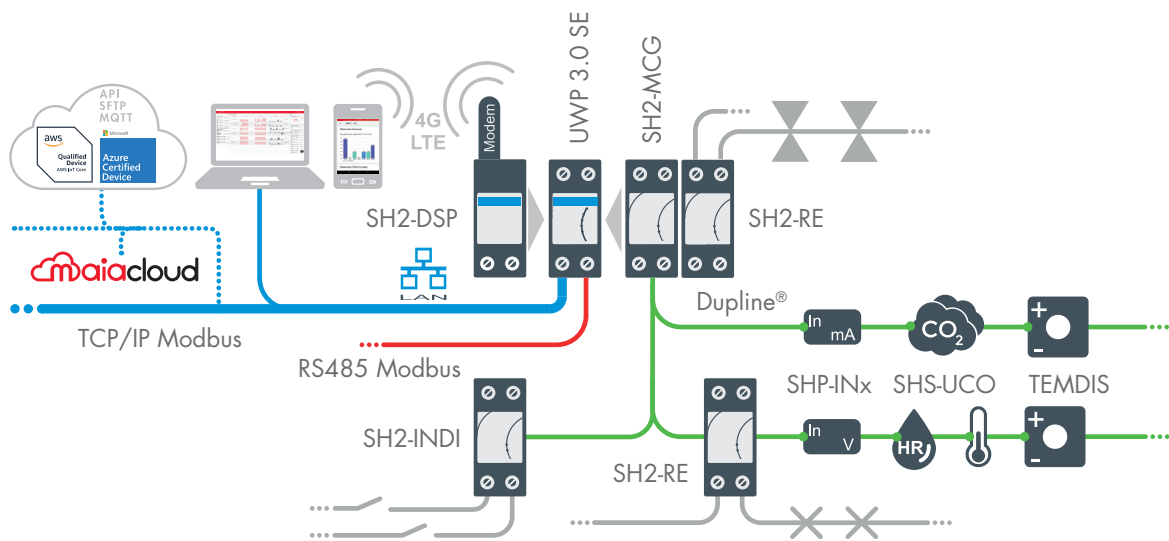

SHSU

- Room sensors for CO₂, temperature and humidity measurement
- Available with/ without display, or RGB LED
- Temperature range: -20 – +50 °C
- Humidity range: 0 – 100 %RH
- CO₂ range: 0 – 2000 ppm
- Easily mountable
- Dupline® bus powered
- Low energy consumption



SHP-INx, SH2-INDI

- SHP-INV3: 3*0 – 10 V adjustable inputs
- SHP-INA2: 2*0/4-20 mA adjustable inputs
- SHP-INV2T1P1: 2*0-10 V dc + 10K3 thermistor + 1-11 kΩ inputs, 24 V dc powered
- SHP INT: Pt1000, Ni1000, 10K3 thermistor, 1-11 kΩ potentiometer inputs, Bus-powered
- SHP IN: 4 contact ON/OFF/counter inputs. Count reset via Dupline® (optional)
- SH2-INDI: 4 PNP/NPN/contact inputs also with counter function, Bus-powered in 2-DIN modules



SHx-TEMDIS

- Temperature controller with display
- Shows current room, outdoor, and auxiliary temperature
- Turns ON/OFF heating and cooling
- Energy Save through 3 different setpoints: comfort, activity, economy
- Dupline® bus powered
- SHA4: designed to fit into wall socket from Fuga, Niko, and BTicino
- SHE5: designed to fit into wall socket from Elko, Gira, Schneider, Siemens, and Jung



SH2-RE

- 2 or 4 relay outputs with embedded energy analyzer
- LED-indications for power supply, bus and outputs status
- Push button for local ON/OFF switching
- 2-DIN module housing
- 230 V ac power supply, Dupline® bus powered, 24 V dc
- Connection to other cabinet modules via local bus

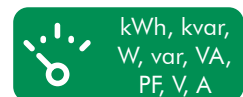

OUR SALES NETWORK IN EUROPE

AUSTRIA

Carlo Gavazzi GmbH
Ketzerergasse 374,
A-1230 Wien
Tel: +43 1 888 4112
Fax: +43 1 889 1053
office@carlogavazzi.at

BELGIUM

Carlo Gavazzi NV/SA
Mechelsesteenweg 311,
B-1800 Vilvoorde
Tel: +32 2 257 41 20
sales@carlogavazzi.be

DENMARK

Carlo Gavazzi Handel A/S
Over Hadstensevej 40,
DK-8370 Hadsten
Tel: +45 89 60 61 00
Fax: +45 86 98 15 30
handel@gavazzi.dk

FINLAND

Carlo Gavazzi OY AB
Ahventie, 4 B
FI-02170 Espoo
Tel: +358 9 756 2000
myynti@gavazzi.fi

FRANCE

Carlo Gavazzi Sarl
Zac de Paris Nord II, 69, rue de la Belle Etoile,
F-95956 Roissy CDG Cedex
Tel: +33 1 49 38 98 60
Fax: +33 1 48 63 27 43
french.team@carlogavazzi.fr

GERMANY

Carlo Gavazzi GmbH
Pfnorstr. 10-14
D-64293 Darmstadt
Tel: +49 6151 81 00 0
Fax: +49 6151 81 00 40
info@gavazzi.de

GREAT BRITAIN

Carlo Gavazzi UK Ltd
4.4 Frimley Business Park,
Frimley, Camberley, Surrey GU16 7SG
Tel: +44 1 276 854110
Fax: +44 1 276 682140
sales@carlogavazzi.co.uk

ITALY

Carlo Gavazzi SpA
Via Milano, 13,
I-20045 Lainate
Tel: +39 02 931 76 1
Fax: +39 02 931 76 301
info@gavazziacbu.it

NETHERLANDS

Carlo Gavazzi BV
Wijkermeerweg 23,
NL-1948 NT Beverwijk
Tel: +31 251 22 93 45
Fax: +31 251 22 60 55
info@gavazzi.nl

NORWAY

Carlo Gavazzi AS
Melkeveien 13,
N-3919 Porsgrunn
Tel: +47 35 93 08 00
Fax: +47 35 93 08 01
post@gavazzi.no

PORTUGAL

Carlo Gavazzi Lda
Rua dos Jerónimos 38-B,
P-1400-212 Lisboa
Tel: +351 21 361 70 60
Fax: +351 21 362 13 73
carlogavazzi@carlogavazzi.pt

SPAIN

Carlo Gavazzi SA
Avda. Iparraguirre, 80-82,
E-48940 Leioa (Bizkaia)
Tel: +34 94 480 40 37
Fax: +34 94 431 60 81
gavazzi@gavazzi.es

SWEDEN

Carlo Gavazzi AB
V:a Kyrkogatan 1,
S-652 24 Karlstad
Tel: +46 54 85 11 25
Fax: +46 54 85 11 77
info@carlogavazzi.se

SWITZERLAND

Carlo Gavazzi AG
Verkauf Schweiz/Vente Suisse
Sumpfstrasse 3,
CH-6312 Steinhausen
Tel: +41 41 747 45 35
Fax: +41 41 740 45 40
info@carlogavazzi.ch

OUR SALES NETWORK IN THE AMERICAS

USA

Carlo Gavazzi Inc.
750 Hastings Lane,
Buffalo Grove, IL 60089-6904, USA
Tel: +1 847 465 61 00
Fax: +1 847 465 73 73
sales@carlogavazzi.com

CANADA

Carlo Gavazzi Inc.
2660 Meadowvale Boulevard,
Mississauga, ON L5N 6M6, Canada
Tel: +1 905 542 0979
Fax: +1 905 542 2248
gavazzi@carlogavazzi.com

MEXICO

Carlo Gavazzi Mexico S.A. de C.V.
Circuito Puericultores 22, Ciudad Satelite
Naucalpan de Juárez, Edo Mex. CP 53100
Mexico
T +52 55 5373 7042
F +52 55 5373 7042
mexicosales@carlogavazzi.com

BRAZIL

Carlo Gavazzi Automação Ltda.
Av. Francisco Matarazzo, 1752
Conj 2108 05001-200 - São Paulo - SP
Tel: +55 11 3052 0832
Fax: +55 11 3057 1753
info@carlogavazzi.com.br

OUR SALES NETWORK IN ASIA AND PACIFIC

SINGAPORE

Carlo Gavazzi Automation Singapore Pte. Ltd.
61 Tai Seng Avenue #05-06
Print Media Hub @ Paya Lebar iPark
Singapore 534167
Tel: +65 67 466 990
Fax: +65 67 461 980
info@carlogavazzi.com.sg

MALAYSIA

Carlo Gavazzi Automation (M) SDN. BHD.
D12-06-G, Block D12,
Pusat Perdagangan Dana 1,
Jalan PJU 1A/46, 47301 - Petaling Jaya,
Selangor, Malaysia
Tel: +60 3 7842 7299
Fax: +60 3 7842 7399
info@gavazzi-asia.com

CHINA

Carlo Gavazzi Automation
(China) Co. Ltd.
Unit 2308, 23/F.,
News Building, Block 1, 1002
Middle Shennan Zhong Road, Futian District,
Shenzhen, China
Tel: +86 755 8369 9500
Fax: +86 755 8369 9300
sales@carlogavazzi.cn

HONG KONG

Carlo Gavazzi Automation
Hong Kong Ltd.
Unit No. 16 on 25th Floor, One Midtown,
No. 11 Hoi Shing Road, Tsuen Wan,
New Territories, Hong Kong
Tel: +852 26261332 / 26261333
Fax: +852 26261316

TAIWAN

Branch of Carlo Gavazzi Automation
Singapore Pte. Ltd.
22F-1, No.500 Shizheng Rd, Xitun Dist,
Taichung City 407,
Taiwan, China
Tel. +886 4 2258 4001
Fax +886 4 2258 4002

OUR COMPETENCE CENTRES AND PRODUCTION SITES

DENMARK

Carlo Gavazzi Industri A/S
Hadsten

MALTA

Carlo Gavazzi Ltd
Zejtun

ITALY

Carlo Gavazzi Controls SpA
Belluno

LITHUANIA

Uab Carlo Gavazzi Industri Kaunas
Kaunas

CHINA

Carlo Gavazzi Automation (Kunshan) Co., Ltd.
Kunshan

HEADQUARTERS

Carlo Gavazzi Automation SpA
Via Milano, 13
I-20045 - Lainate (MI) - ITALY
Tel: +39 02 931 76 1
info@gavazziautomation.com

Energy to Components!

www.gavazziautomation.com